

SAC2411

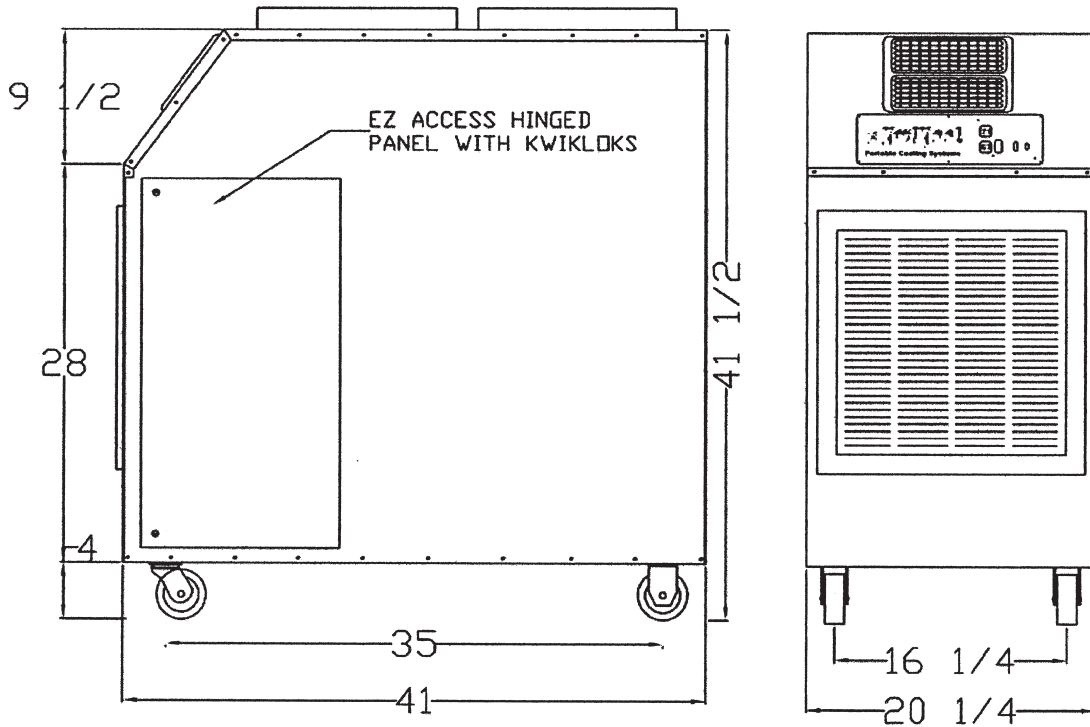
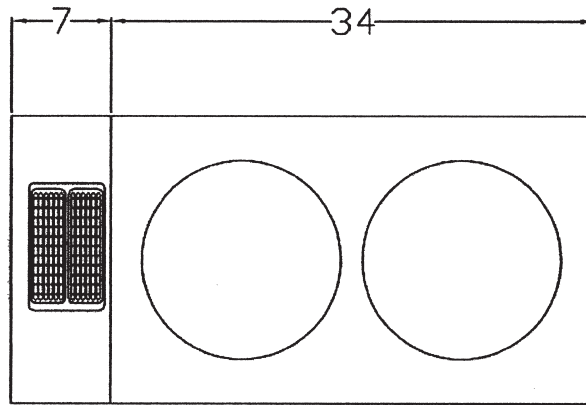

COOLING CAPACITY		
	BTU/hr @ 95°F at 60% RH	23,500 (2 Ton)
COMPRESSOR DATA		
	Compressor Type	Hermetic Recip.
	Operating Temperatures	60°F-110°F 50% RH
FAN DATA		
EVAPORATOR		
	Fan Type (Centrifugal)	Direct Drive
	Air Flow (CFM) / Speeds	725/1
	Supply Air Data	Louver
	Supply Air Chute Max. Length	N/A
	Motor HP	1/5
CONDENSER		
	Fan Type (Centrifugal)	Direct Drive
	Air Flow (CFM)	1350
	Condenser Hose Data	2 - 14"x8'
	Condenser Hose Max. Length	25'
	Motor HP	1/3
ELECTRICAL DATA		
	Power Supply (Volts)	115-1Ø
	Current Consumption (Amps)	19.5
	Power Consumption (KW)	1..9
	Circuit Breaker Size (Amps)	20
	Min/Max Voltage	105-125
	Power Cord Guage/Length	12AWG/6'
	Plug Configuration	NEMA 5-20
DIMENSIONAL DATA		
	Width (Inches)	20.25"
	Depth (Inches)	41
	Height (Inches)	41.5"
	Weight (Pounds)	304
	Shipping Weight (Pounds)	334
SAFETY DEVICE DATA		
	Compressor Overload	Internal
	Fan Motor Overload	Automatic Internal
	Evaporator Freeze-up	Constant Pressure/Fan Control
	High Pressure	Manual
	Low Pressure	Automatic
	Compressor Short Cycle	Yes
	Automatic Restart	Yes
	Thermostat	Digital Microprocessor
	Condensate Pump Overflow	Yes
	Condensate Tank Overflow	Yes