

KCW-4221 3.5-Ton

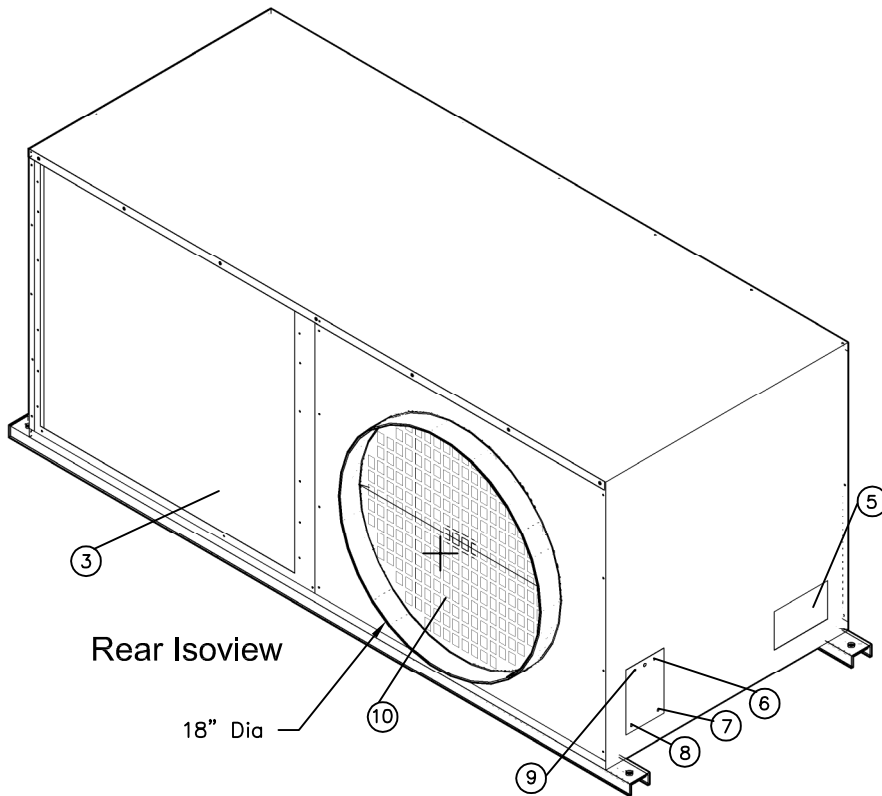

Rear Isoviev

Legend

- 1 Electrical Box
- 2 Cold Air Supply (12in)
- 3 Condenser Intake
- 4 $\frac{1}{2}$ " Female Water Hose Connector (Inlet/Outlet)
- 5 Charging Port
- 6 High Pressure Reset Switch
- 7 Power Input Connection
- 8 Hi-Lo
- 9 Drain Line- $\frac{1}{4}$ "
- 10 Return Air Grill (18in)

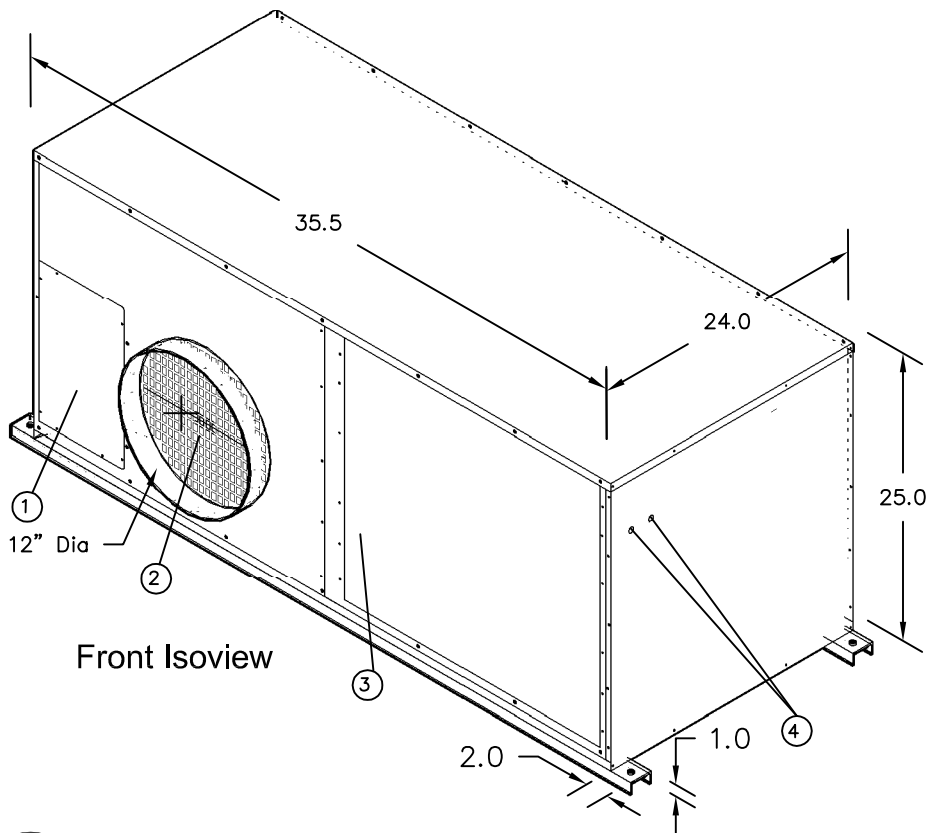

Front Isoviev



ETL LISTED CONFORMS TO ANSI/UL
1995 CERTIFIED TO CAN/CSAA22.2 NO.235

KwikKool

1-800-KWIKOOL

Model KCW4221 - 3.5 Ton

COOLING CAPACITY		
	BTU/hr @ 95 F at 60%RH	42,000 (3.5 TONS)
COMPRESSOR DATA		
	Compressor Type	HERMETIC RECIP.
	Operating Temperatures	60-110 F .50%RH
	Non-CFC Refrigerant Charge (Lbs.)	407C
FAN DATA		
EVAPORATOR		
	Fan Type (Centrifugal)	DIRECT DRIVE
	Air Flow (CFM)	1400
	Cold Air Supply Diameter (Inches)	12 In.
	Cold Air Return Diameter (Inches)	18 In.
	Motor HP	1/2
WATER FLOW DATA		
	Flow Regulation Valve	AUTOMATIC
	Inlet Water 85F-95F Exit(GPM)	10.5
	Inlet Water 75F-95F Exit(GPM)	5.25
	Inlet Water 65F-95F Exit(GPM)	3.5
	Inlet Water 55F-95F Exit(GPM)	2.75
ELECTRICAL DATA		
	Power Supply (Volts)	208/230-Single Phase
	Current Consumption (Amps)	28/25.5
	Power Consumption (KW)	5
	Maximum Circuit Breaker (Amps)	40 at 208-V/30 at 230-V
	Minimum Circuit Ampacity (Amps)	25.25
	Min/Max Voltage	195-225/210-250
DIMENSIONAL DATA		
Unitary Models	Width x Depth x Height (Inches)	24X35.5X25
	Weight (Lbs.)	238.5
	Shipping Weight (Lbs.)	313.5
SAFETY DEVICE DATA		
	Compressor Overload	INTERNAL
	Fan Motor Overload	AUTOMATIC INTERNAL
	Evaporator Freeze-up	HOT GAS BYPASS
	High Pressure Switch	MANUAL
	Low Pressure Switch	AUTOMATIC
	Compressor Short Cycle	YES
	Automatic Restart	YES
	Thermostat	Customer Supplied
	Condensate Pump w 20' Head Pres.	YES
	Condensate Pump Overflow	YES
	Condensate Tank Overflow	YES