

KCA-6023 5.0-Ton

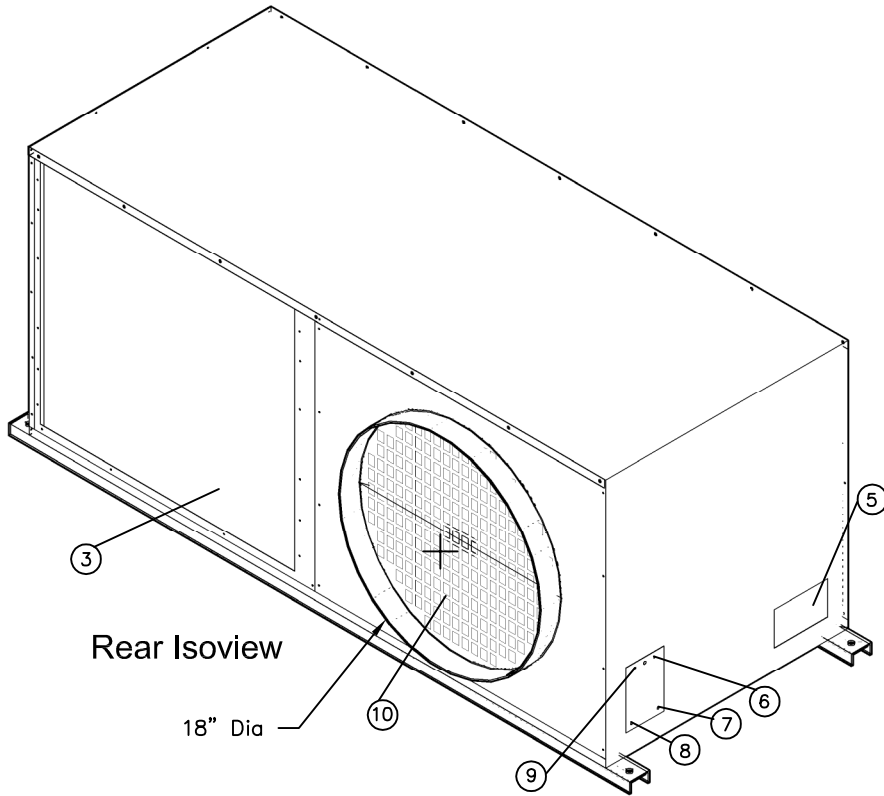

Rear Isoviev

Legend

- 1 Electrical Box
- 2 Cold Air Supply (12in)
- 3 Condenser Intake
- 4 Condenser Exhaust(16in)
- 5 Charging Port
- 6 High Pressure Reset Switch
- 7 Power Input Connection
- 8 Hi-Lo
- 9 Drain Line- $\frac{1}{4}$ "
- 10 Return Air Grill (18in)

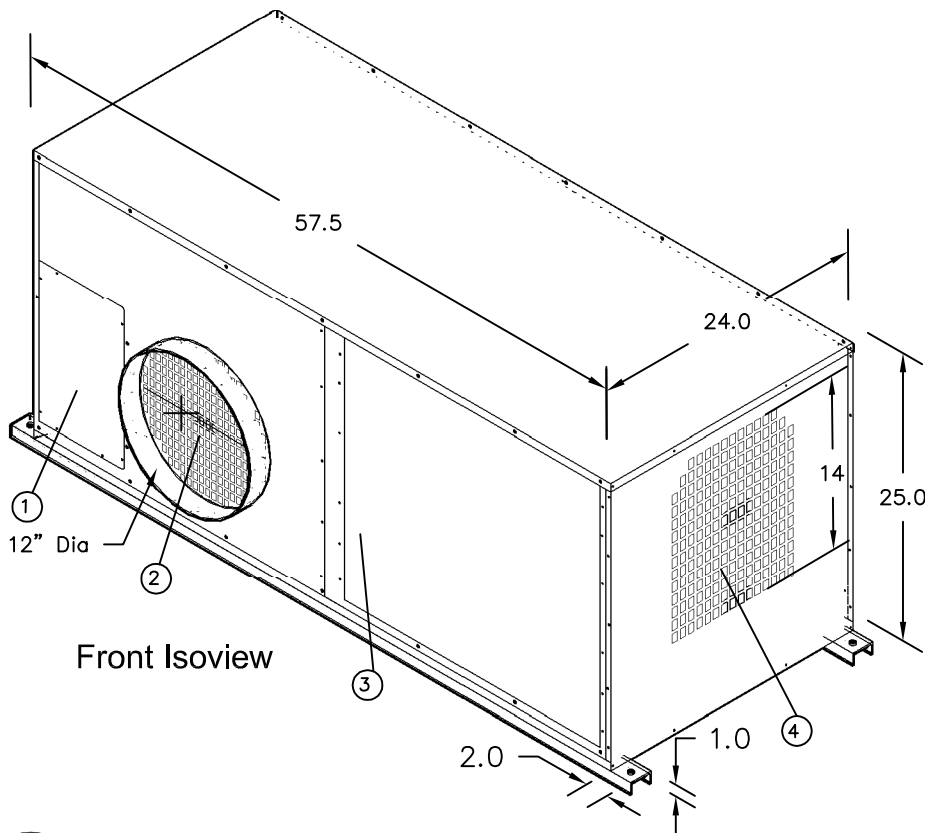

Front Isoviev



ETL LISTED CONFORMS TO ANSI/UL
1995 CERTIFIED TO CAN/CSAA22.2 NO.235



1-800-KWIKOOL

Model KCA6023 - 5 Ton

COOLING CAPACITY		
	BTU/hr @ 95 F at 60%RH	60000 (5 TON)
COMPRESSOR DATA		
	Compressor Type	HERMETIC RECIP.
	Operating Temperatures	60-110 F .50%RH
	Non-CFC Refrigerant Charge (Lbs.)	407C
FAN DATA		
EVAPORATOR		
	Fan Type (Centrifugal)	DIRECT DRIVE
	Air Flow (CFM)	2000/3 Speed
	Cold Air Supply Diameter (Inches)	12 In.
	Cold Air Return Diameter (Inches)	18 In.
	Motor HP	1
CONDENSER		
	I/O Intergral Condenser - In/Out	BALANCED AIR FLOW
	Fan Type (Centrifugal)	HTD DIRECT DRIVE
	Air Flow (CFM)	3500
	Condenser Flange (In.)	16 In.
	Condenser Duct Max. Length	65'
	Motor HP - 2 - Dual Direct Drive	1
ELECTRICAL DATA		
	Power Supply (Volts)	208-230 - 3 Phase
	Current Consumption (Amps)	38.8/35.3
	Power Consumption (KW)	7.5
	Maximum Circuit Breaker (Amps)	50/40
	Minimum Circuit Ampacity (Amps)	38.5
	Min/Max Voltage	195-225/210-250
DIMENSIONAL DATA		
Unitary Models	Width x Depth x Height (Inches)	24X57.5X25 w/o Mount
	Weight (Lbs.)	435
	Shipping Weight (Lbs.)	510
SAFETY DEVICE DATA		
	Compressor Overload	INTERNAL
	Fan Motor Overload	AUTOMATIC INTERNAL
	Evaporator Freeze-up	HOT GAS BYPASS
	High Pressure Switch	MANUAL
	Low Pressure Switch	AUTOMATIC
	Compressor Short Cycle	YES
	Automatic Restart	YES
	Thermostat	Customer Supplied
	Condensate Pump w 20' Head Pres.	YES
	Condensate Pump Overflow	YES
	Condensate Tank Overflow	YES