



342 N. Co. Rd. 400 East
Valparaiso, IN 46383
888-432-8924 • Fax 219-462-7985
www.heatwagon.com

Installation and Maintenance Manual

Please retain this manual for future reference.

VG400

Construction Heater



City of New York
Dept. of Buildings
29-05-E



CAUTION: Do not use this heater in a space where gasoline or other liquids having flammable vapors are stored.

IMPORTANT INFORMATION! READ FIRST

The heater is designed for use as a construction heater under ANSI Z83.7a-2000. Heater is not intended for use in pest remediation. The primary purpose of construction heaters is to provide temporary heating of buildings under construction, alteration, or repair and to provide emergency heat. Properly used, the heater provides safe, economical heating. Products of combustion are vented outside the area being heated.

The heater **IS NOT** designed as an Unvented Gas Fired Room Heater under ANSI-Z21.11.2 and **SHOULD NOT** be used in the home.

ANSI A119.2(NFPA 501C)-1987 Recreational Vehicle Standard prohibits the installation or storage of LP-gas containers even temporarily inside any recreational vehicle. The standard also prohibits the use of Unvented Heaters in such vehicles.

NFPA-58 1989 STANDARD FOR THE STORAGE AND HANDLING OF LIQUEFIED PETROLEUM GASES

Use of the heater must be in accordance with this Standard and in compliance with all governing state and local codes. Storage and handling of propane gas and propane cylinders must be in accordance with NFPA 58 and all local governing codes.

We cannot anticipate every use which may be made for our heaters. **CHECK WITH YOUR LOCAL FIRE SAFETY AUTHORITY IF YOU HAVE QUESTIONS ABOUT LOCAL REGULATIONS.**

Other standards govern the use of fuel gases and heat producing products in specific applications. Your local authority can advise you about these.

CAUTION

DO NOT USE THIS HEATER IN A SPACE WHERE GASOLINE OR OTHER LIQUIDS HAVING FLAMMABLE VAPORS ARE STORED OR USED.

CONSTRUCTION HEATER GENERAL HAZARD WARNING:

Failure to comply with the precautions and instructions provided with this heater, can result in death, serious bodily injury and property loss or damage from hazards of fire, explosion, burn, asphyxiation, carbon monoxide poisoning, and/or electrical shock.

Only persons who can understand and follow the instructions should use or service this heater.

If you need assistance or heater information such as an instruction manual, labels, etc., contact your local Heat Wagon dealer or the manufacturer.

W A R N I N G

Fire, burn, inhalation, and explosion hazard. Keep solid combustibles, such as building materials, paper or cardboard, a safe distance away from the heater as recommended by the instructions. Never use the heater in spaces which do or may contain volatile or airborne combustibles, or products such as gasoline, solvents, paint thinner, dust particles or unknown chemicals.

Not for home or recreational vehicle use!

If you have read this entire manual and you still have questions, please call us at 219-464-8818

Installation and Maintenance Manual

Model VG400

Construction Heater

Table of Contents:

	Page
Safety & Caution	3
Specifications	3
Operating Instructions	4
Maintenance	7
Troubleshooting	9
Illustrated Parts Breakdown	14-16
Wiring Diagrams	16-19
Exhaust Flue Pipe Guidelines	20

WARRANTY

This heater is guaranteed against defective materials and workmanship for one (1) year from Heat Wagon invoice date.

Warranty repairs may be made only by an authorized, trained and certified Heat Wagon dealer. Warranty repairs by other entities will not be considered. Warranty claims must include model number and serial number. Components are guaranteed to the extent of the component manufacturer's warranty.

LIMITATIONS

Warranty claims for service parts (wear parts) such as spark plugs, igniters, and flame rods will not be allowed. Diagnostic parts such as voltage meters and pressure gauges are not warrantable. Evidence of improper fuel usage, fuel pressures outside of manufacturer's specification, poor fuel quality, improper electric power, misapplication and/or evidence of abuse may be cause for rejection of warranty claims.

Labor, travel time, mileage and shipping charges will not be allowed. Minor adjustments to heaters are the responsibility of the dealer. Defective parts must be tagged and held for possible return to the factory for 60 days from date of repair. The factory will provide a return goods authorization, (RGA) for defective parts to be returned. No warranty will be allowed for parts not purchased from Heat Wagon.



342 N. Co. Rd. 400 East • Valparaiso, IN 46383
219-464-8818 • 888-432-8924 • Fax 800-255-7985
www.heatwagon.com

SAFETY & CAUTION

- Instructions given in this manual and the applicable regulations of the local authorities must be followed.
- The unit may be operated only by those persons who have been instructed in its proper use.
- The unit is to be installed and operated in such a way as to ensure the safety of employees and surroundings.
- Never cover the unit's air openings.
- Always ensure adequate fresh air supply to the unit.
- Never stand in front of the discharge end of the heater.
- Keep a minimum clearance of 10 feet from the fuel source. Storing and use of liquid fuel must comply with the regulations and instructions given by the local authorities.
- Unit's emitted noise level at the range of 3 feet: 74 dBA.
- Do not introduce foreign objects into the unit.
- Do not expose the unit to direct water jets.
- All electric cables outside the unit are to be protected against damage.
- Always disconnect the unit from power supply and turn off the gas supply when maintenance or service is being performed.
- **IF NOT OPERATED WITHIN GUIDELINES OF THESE OPERATING INSTRUCTIONS, MANUFACTURER WILL NOT BE HELD RESPONSIBLE AND WARRANTY WILL BECOME VOID.**

SPECIFICATIONS

Model No. VG400

Fuels:	Vapor Propane or Natural Gas
Capacity:	400,000 BTU/HR
Blower:	2,100 CFM 1/2" SP
Electrical Rating:	120 Volts, 10 Amps
Fuel Consumption:	NG-400 CFH / Propane-4.4 GPH
Gas Connection:	3/4" FNPT
Remote Thermostat:	On/Off
Max. Discharge Temp.:	200°F @ 0°F Ambient
Duct Size:	12" Dia., 50 ft. max (straight), temp. rating 225°F min.
Actual Dimensions:	60"L x 24"W x 45"H
Shp. Dimensions:	70"L x 33"W x 54"H
Weight (approximate):	400 lbs.

Gas Supply:	Inlet Pressure		Manifold Pressure	Burner Orifice
	Max W.C.	Min W.C.	W.C.	
Vapor Propane	14" W.C.	9" W.C.	4"	.332
Natural Gas	14" W.C.	9" W.C.	4"	.468

Note: 1 pound per square inch (psi) = 28" W.C. (water column)

OPERATING INSTRUCTIONS

INSTALLATION

- When transporting, use both lifting eyes located on sides of heater.
- Place the unit on a level and non-combustible surface.
- Minimum clearances from combustibles:
 - outlet, minimum 10 feet
 - sides, minimum 3 feet
 - top, minimum 3 feet
 - flue pipe exhaust minimum 2 feet
- If the unit is placed indoors, secure an adequate fresh air opening for the burner combustion air.
- The unit may not be installed and operated in premises where explosive or combustible fumes or dust are present. Always check the regulations of local authorities.
- Be certain that neither the air inlet nor the air outlet is obstructed.

FUEL SUPPLY

For supply pressures greater than 1/2psi

- A regulator must be installed on the heater to ensure that the pressure to the heater does not exceed 1/2 psi inlet pressure. Excessive pressures over 1/2 psi (14" W.C.) will damage controls and void warranty.

- This heater is shipped as either natural gas or vapor propane. Check for proper burner orifice in burner.

Vapor Propane	.332
Natural Gas	.468

- Be certain to use adequate hose or pipe size to ensure proper volume and pressure.
See Chart Below.

VAPOR PROPANE QUICK REFERENCE HOSE CHART

(Tank sizing chart
on page 21)

Hose Length in Feet	BTU 400,000	
	1/2PSI	10PSI
10	3/4	3/4
25	3/4	3/4
35	1-1/4	3/4
50	1-1/4	3/4
75	1-1/4	3/4
100	1-1/4	3/4
125	1-1/4	3/4
150	1-1/4	3/4
175	1-1/4	3/4
200	1-1/4	3/4
225	1-1/4	3/4

NATURAL GAS QUICK REFERENCE HOSE CHART

Hose Length in Feet	BTU 400,000		
	<1PSI	2PSI	5PSI
10	3/4	3/4	-
25	1-1/4	3/4	-
35	1-1/4	3/4	-
50	-	3/4	-
75	-	3/4	-
100	-	3/4	-
125	-	3/4	-
150	-	3/4	-
175	-	3/4	-
200	-	3/4	-
225	-	3/4	-

FUEL SUPPLY (CONTINUED)

- For proper propane tank sizing see page 21.
- Visually inspect the hose assembly and ensure that it is protected from traffic, building materials, and contact with hot surfaces. If it is evident that there is excessive abrasion or wear, or the hose is cut, replace it immediately.
- Purge air from line and wait 10 minutes for gas to dissipate.
- After installation, check the hose assembly for gas leaks by applying a water and soap solution to each connection.
- Fuel hose must be UL approved.
- The installation of this heater to a natural gas supply must confirm with all applicable local codes or, in the absence of local codes, with the *National Fuel Gas Code ANSI Z223.1/NFPA 54*. For vapor propane, refer to standard for *Storage and Handling of Liquefied Petroleum Gases ANSI/NFPA 58*.

ELECTRICAL

- Electric cable extensions must be connected based on the unit capacity and cable length.
- We highly recommend a dedicated line, 15 amp minimum.
- Confirm voltage at heater connection (105V min.) to ensure proper operation.

EXHAUST FLUE PIPE

- The unit is to be connected to a flue pipe with adequate draft, to ensure the proper start and operation of the unit. Refer to page 20.
- The flue pipe and its installation must comply with the regulations and instructions given by the local authorities.
- A flue pipe must be used at all times. You must increase flue pipe diameter if its is longer than 26"

DISCHARGE DUCTING (Warm Air)

- Minimum clearance from combustible materials is 4 inches.
- Use steel ducting or fabric ducting capable of withstanding maximum temperature of 225°F.
- Maximum length of duct: 50' (straight).
- Duct diameter: 12".
- Make sure that the duct is safely and properly fastened to the outlet.
- Avoid sharp bends and corners to ensure maximum air flow and avoid back pressure/heat accumulation in heater.
- Do not exceed 1/2" w.c. of back pressure.
- FAILURE TO COMPLY WITH THESE RECOMMENDATIONS COULD RESULT IN SHUTDOWN OF THE HEATER.

START UP

- Only people trained in the operation and supervision of this heater should operate and maintain the unit.
- Check the unit to make sure that there are no visible defects on the control and safety devices and that the unit has been installed correctly.
 1. Check that the control switch on the control box is in position "0" (STOP).
 2. Pre-select desired room temperature on the remote thermostat. The temperature must be set higher than the ambient temperature.
 3. Open all possible shut-off devices of the fuel supply lines.
 4. Turn the control switch on the control box to position "1" (HEATING).
 5. When the ambient temperature level is low, the burner switches on automatically. The fan does not switch on until the set temperature (104°F) of the heat-exchanger has been reached (will take approximately 1-5 minutes).
- After startup, the heater is operated automatically by the room thermostat and governed by all control devices, including the safety limit controls.
- The room thermostat and burner sensor control the running sequences of the burner and the fan sensor controls the fan function.
- Overheat limit reset controls and shuts off the heater (burner) in the case of overheating.
- The unit can also be used for ventilation purposes only, if needed.
 1. Turn the control switch on the control box to position "2" (VENTILATION).
 2. The unit is now in the continuous ventilating mode.
 3. Heating is not possible in this mode.

SHUT DOWN

- Turn control switch to position "0" (STOP).
- If moving the heater, close fuel supply followed by turning control switch to position "0" (Stop).

Important!

The air supply fan continues running to cool down the combustion chamber/heat exchanger and then stops later. The fan can restart for several times before finally switching off!

WARNING!

UNIT MAY BE UNPLUGGED IN EMERGENCY SITUATIONS ONLY. OTHERWISE, DO NOT STOP THE UNIT BY UNPLUGGING IT. UNIT NEEDS TO COOL DOWN USING ITS OWN FAN. FAILURE TO COMPLY WITH PROPER SHUT-DOWN PROCEDURES CAN CAUSE DAMAGE TO THE COMBUSTION CHAMBER, HEAT EXCHANGER, SAFETY FEATURES AND WILL VOID WARRANTY.

MAINTENANCE

Prior to starting any maintenance work be sure to disconnect unit from power supply after the unit cools down fully and fan shuts off! (Shut Down Procedures page 6)

To ensure the proper function of the unit, it must be serviced on regular basis. Maintenance can be performed, excluding the control devices and safety limit controls, by an authorized trained & certified Heat Wagon dealer. The control devices and safety limit controls do not need routine maintenance. If these items fail they must be replaced.

- Do not use any aggressive cleaning agents, which are harmful or environmentally unfriendly, when cleaning the unit.
- Do not use water jet when cleaning the unit.
- Pressurized air may be used for maintenance. Be careful not to damage the fan blower wheel with too much pressure (<30 psi).
- Check whether the unit is free from mechanical damage, replace faulty parts as necessary.
- *Check fan blower wheel of the fan at regular intervals and clean it with a small brush when needed, especially in a dusty (drywall) environment.*
- Check functionality of control and safety devices regularly.
- Have the flue gas values of the burner checked regularly by authorized agents.
- Be sure to store the unit in a dust free and dry place when it is not used for a long period of time. Cover the exhaust flue to prevent entry of foreign objects.

SERVICE

- The complete unit, including heat exchanger, combustion chamber and burner should be cleaned from dust and dirt after every heating period, at a minimum of once per year.

-Removal of combustion chamber/heat exchanger:

For proper cleaning of the unit, manufacturer recommends removal of the complete combustion chamber with heat exchanger. Clean combustion chamber and exchanger tube with brush. Vacuum all loose ash and soot. Close all cleaning flanges carefully to avoid damage to gasket material.

-Disassembling of burner:

1. Disassemble four tightening bolts on the combustion chamber flange and remove burner's mounting flange. Take care not to damage the flange gasket.
2. Pull out the burner. Take care not to damage the burner head and power cable. Clean blower wheel, ignitor electrode, flame sensor and photocell.

Refer to page 16 for burner settings.

VG400 TROUBLESHOOTING**Symptom**

1. Turn the heater to position #1 and nothing happens.

Possible Causes

- Power supply cord
- Thermostat
- Overheat limit switch is tripped
- 24 volt transformer
- Burner motor relay
- Burner sensor
- Heater control unit (HCU)

Possible Solutions

- Test for 120 volts between L1 and N on the main terminal block.
- Turn thermostat above ambient temperature.
- Reset switch, located on the right hand corner (facing the right hand side of the unit or at location #26 on page 14) .
- Using a volt meter, check for 24 volts AC between ground and one of the "T" terminals on the Honeywell control. If less than 24 replace transformer.
- Turn on the heater. Check for 120 volts between ground and both black wires on the relay. Relay is located in the burner control box under the flame safeguard control. If less than 105 replace relay.
- On the heater control unit (HCU) disconnect the wires from terminals X10 and X11. Using an ohm meter, check the resistance between the two wires for a reading. Compare to Sensor Resistance Chart page 17. Replace sensor if out of range.
- On the main terminal block, check for 120 volts between terminals 8 and N when the 3-position switch is in the HEAT position. If less than 105 replace HCU.

2. The heater runs for a little while, but shuts down. It won't come on again until I reset the limit switch.

- Burner orifice is improperly sized
- Incorrect burner manifold pressure
- Restricted airflow (will trip overheat limit switch)
- Overheat limit switch faulty due to loss of power
- Overheat limit
- Improper flue piping or improper ducting

- For propane, use size .332
- For natural gas, use size .468
- Use a low pressure gauge (0-15 inches of water column) with a 1/8" NPT inlet. Install gauge in the pressure tap port located on the output side (see page 14) of the gas valve. Run the heater. Adjust the pressure by turning the pressure adjusting screw (located on the input side top of the gas valve) counter clockwise until the gauge reads 4" W.C. (see page 14)
- Check for dirt or ice buildup on the air inlet or blower wheel. If using duct on the air outlet, insure the back pressure does not exceed a static pressure of .5" W.C. Check with low pressure gauge if necessary (0-15 inches of water column). Confirm proper installation of flue pipe - page 20
- Adhere to the proper shut down procedures. Power must remain at the unit until it cools down fully. Blower will shut down on its own when cool. Test overheat limit switch for continuity between the two male terminals at room temperature. Replace if overheat limit switch fails test.
- Check for proper installation/restriction in flue piping or discharge duct.
- Refer to page 20 for proper flue piping. Duct (hose) needs to be free of 90° bends.

VG400 TROUBLESHOOTING

Symptom

3. The heater has a loud rumbling sound.

Possible Causes

- Air damper setting
- Dirt on burner blower wheel
- Flue pipe setup or flue pipe restrictions
- Gas manifold pressure

Possible Solutions

- Rough setting at 4-6. Minor adjustments from the rough settings can be made to achieve a smooth sounding burner with no soot from the flue pipe.
- Clean the burner blower wheel with a small brush and compressed air.
- Refer to the flue pipe chart in this manual. (page 20) Check flue for restriction.
- Use a low pressure gauge (0-15 inches of water column) with 1/8" NPT inlet. Install gauge in the pressure tap port located on the output side of the gas valve. Run the heater. Adjust the pressure by turning the pressure adjusting screw (located on the input side top of the gas valve) until the gauge reads 4" W.C. Refer to pipe sizing charts in the Heat Wagon Engineering guide, Heater requires 9-14" W.C. inlet pressure. Ensure proper purge procedure (see fuel supply installation).

• Burner orifice size

- For propane, use size .332.
For natural gas, use size .468.

• Restrict heat exchanger

- Remove flue pipe and use a flashlight to inspect the inside of the heat exchanger. The access panel is located under the heat exchanger. Tilt the heater on the air discharge side, remove the axle, bottom panel and access panel. Clean the inside of the heat exchanger.

4. Burner motor comes on, but the heater won't ignite.

• Fuel pressure or volume

- Use a low pressure gauge (0-15 inches of water column) with 1/8" NPT inlet. Install gauge in the pressure tap port located on the output side of the gas valve. Run the heater. Adjust the pressure by turning the pressure adjusting screw (located on the input side top of the gas valve) until the gauge reads 4" W.C. Refer to pipe sizing charts in the Heat Wagon Engineering Guide. Heater requires 9-14" W.C. inlet pressure.

Continued on next page

• Air inlet damper adjustment

- Rough setting at 4-6. Minor adjustments from the rough settings can be made to achieve a smooth sounding burner with no soot from the flue pipe.

• Ignition electrode

- Clean with fine sandpaper. Make sure it is free from buildup or cracks.
- Turn off the gas valve, turn on the burner. Use insulated pliers to hold the ignition wire and short it to ground. Pull the wire away from ground slowly. A rainbow colored arc should travel between the wire and the ground at a distance of 3/8 of an inch for a duration of 4-5 seconds.

VG400 TROUBLESHOOTING**Symptom****Possible Causes**

4. (Continued)
Burner motor comes on, but the heater won't ignite.

- Burner airflow switch
- Gas valve

Possible Solutions

- The burner airflow switch will not allow power to the flame safeguard control when it is open. Check the tubes supplying air to the switch for any restrictions. ONLY AS A TEST, wire around the air switch. If this test solves the problem, adjust or replace the switch.
- If there is power at the flame safeguard control and no power out to the solenoid valve, replace the flame safeguard control. Check for continuity between the terminals on the low valve coil.

Note: No power will be evident the gas valve for the first 35 sec of burner operation (pre-purge time)

5. The heater blows black smoke out of the vent stack.

- Air damper setting
- Dirt on burner blower wheel
- Improper flue pipe setup or flue pipe restrictions
- Gas manifold pressure
- Incorrect burner orifice size
- Restricted heat exchanger

- Rough setting at 4-6. Minor adjustments from the rough settings can be made to achieve a smooth sounding burner with no soot from the flue pipe.
- Clean the burner blower wheel with a small brush.
- Refer to the flue pipe chart in this manual (page 20). Check flue for restriction.
- Use a low pressure gauge (0-15 inches of water column) with 1/8" NPT inlet. Install gauge in the pressure tap port located on the output side of the gas valve. Run the heater. Adjust the pressure by turning the pressure adjusting screw (located on the input side top of the gas valve) counter clockwise until the gauge reads 4" W.C. Refer to pipe sizing charts in the Heat Wagon Engineering Guide. Heater requires 9-14" W.C. inlet pressure.
- For propane, use size .332.
For natural gas, use size .468.
- Remove flue pipe and use a flashlight to inspect the inside of the heat exchanger. The access panel is located under the heat exchanger. Tilt the heater on the air discharge side, remove the axle, bottom panel and access panel. Remove and clean baffles.

VG400 TROUBLESHOOTING

Symptom

6. The burner seems to cycle on and off more than it should.

Possible Causes

- Gas manifold pressure
- Dirt on main air blower or improper setup of outlet air duct
- Burner sensor
- Heater Control Unit (HCU)

Possible Solutions

- Use a low pressure gauge (0-15 inches of water column) with 1/8" NPT inlet. Install gauge in the pressure tap port located on the output side of the gas valve. Run the heater. Adjust the pressure by turning the pressure adjusting screw (located on the input side top of the gas valve) until the gauge reads 4" W.C. Refer to pipe sizing charts in the Heat Wagon Engineering Guide. Heater requires 9-14" W.C. inlet pressure.
- Check for dirt or ice buildup on the air inlet or blower wheel. If using duct on the air outlet, insure the back pressure does not exceed a static pressure of 5" W.C. Check with low pressure gauge.
- On the heater control unit (HCU) disconnect the wires from terminals X10 and X11. Using an ohm meter, check the resistance between the two wires for a reading. Compare to Sensor Resistance Chart page 17. Replace sensor if reading is out of range.
- If all of the above check good, replace the HCU.

7. The burner starts, but the main fan never comes on.

- Fan sensor
- Heater Control Unit (HCU)
- Blower motor relay
- Current overload on blower motor
- Blower motor

- On the heater control unit (HCU) disconnect the wires from terminals X12 and X13. Using an ohm meter, check the resistance between the two wires for a reading. Compare to Sensor Resistance Chart page 17.
- Turn the 3-position main switch to the fan position. If the blower runs, check the fan sensor. If it is good, replace the HCU.
- Turn the 3-position main switch to the fan position. If the relay pulls in, check for voltage between the L1 and L2 terminals. Then check the voltage between terminals T1 and T2. The voltage should be the same. If it is much lower, replace the relay.
- Turn the 3-position main switch to the fan position. Check for voltage between the 2 solenoid coil terminals on the motor relay. If there is no voltage, the overload is bad. Replace the motor and blower assembly.
- Turn the 3-position main switch to the fan position. Check for voltage between terminals T1 and T2 on the motor relay. If the voltage is good, replace the motor.

VG400 TROUBLESHOOTING**Symptom**

8. The burner continues to run, but the fan cycles on and off.

Possible Causes

- Gas manifold pressure
- Fuel supply pressure and volume
- Fan sensor
- Heater Control Unit (HCU)

Possible Solutions

- Use a low pressure gauge (0-15 inches of water column) with 1/8" NPT inlet. Install gauge in the pressure tap port located on the output side of the gas valve. Run the heater. Adjust the pressure by turning the pressure adjusting screw (located on the input side top of the gas valve) until the gauge reads 4" W.C. Refer to pipe sizing charts page 4 in the Heat Wagon Engineering Guide.
- Use a low pressure gauge (0-15 inches of water column) with 1/8" NPT inlet. Install gauge in the pressure tap port located on the input side of the gas valve. Run the heater. Refer to pipe sizing charts (page 4) in the Heat Wagon Engineering Guide. Heater requires 9-14" W.C. inlet pressure.
- On the heater control unit (HCU) disconnect the wires from terminals X12 and X13. Using an ohm meter, check the resistance between the two wires for a reading. Compare to Sensor Resistance Chart page 17. If the test falls out of this range, replace fan sensor.
- Turn the 3-position main switch to the fan position. If the blower runs, and all of the above tests are good, replace the HCU.

**For additional technical service, please contact your local
Heat Wagon dealer or call 888-432-8924.
Please have your model and serial# available when calling.**

Heat Wagon VG400 Parts List

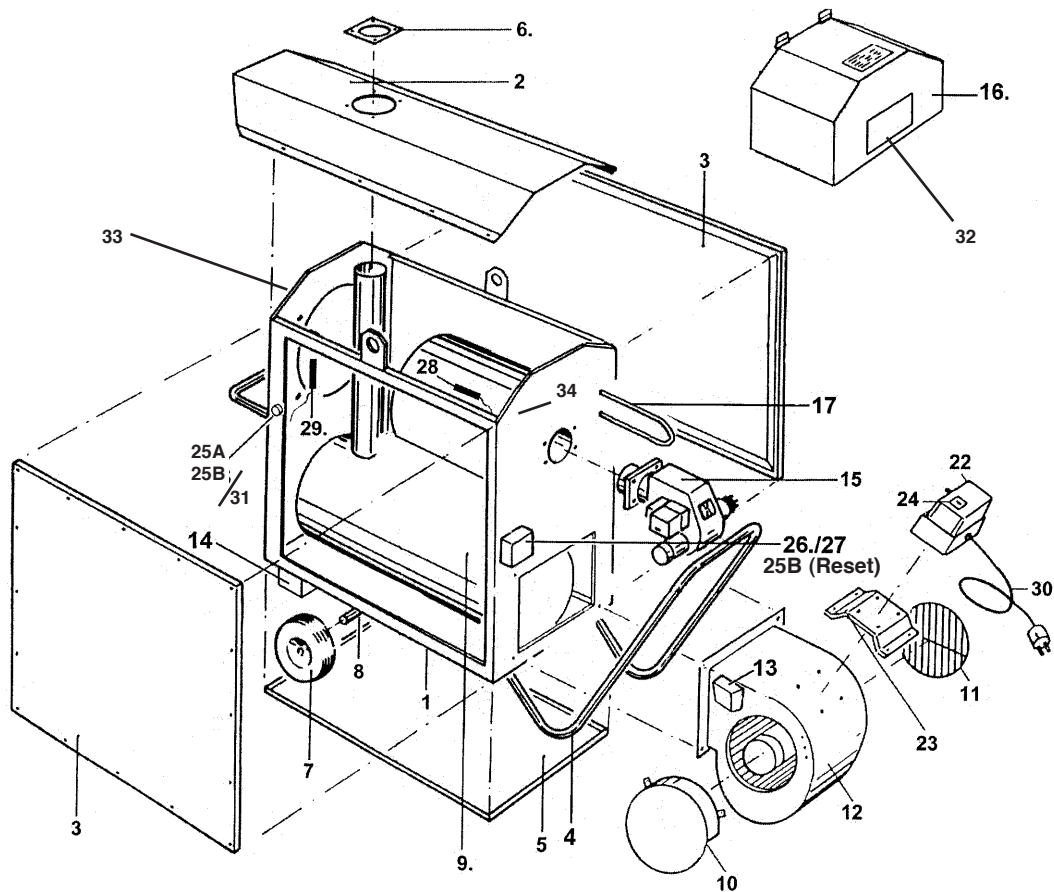

ITEM	PART#	DESCRIPTION	ITEM	PART#	DESCRIPTION
1	HWP 2109001	HEATER FRAME	27	HWP 20579	HEATER CONTROL UNIT
2	HWP 2109002	COVER PLATE	28	HWP 20581	FAN SENSOR (4" SENSOR)
3	HWP 2109003	SIDE PANELS (2)	29	HWP 20582	BURNER SENSOR
4	HWP 2109004	REAR HANDLE	30	HWP HC1020	POWER CORD & PLUG
5	HWP 2109005	BOTTOM PLATE	31	HWP 36811	RUBBER GROMMET
6	HWP 2109006	FLUE COLLAR	32	HWP 210938	PLASTIC WINDOW W/BRACKET
7	HWP HW1065	WHEEL	33	HWP 2109037	12" BLACK OUTLET ADAPTER
8	HWP 2109008	WHEEL SHAFT	34	HWP 20583	FAN SENSOR (8" SENSOR)
9	HWP 2109009	BURNER CHAMBER ASSEMBLY			
10, 11	HWP 2109010	FAN GUARD	NOT SHOWN IN DIAGRAM		
12	HWP 12440	FAN	HWP 2436		CONTACTOR
13	HWP 40900	FAN CONNECTION BOX	HWP 46950		CAPACITOR
14	HWP 2109014	FORKLIFT EYE	HWP 80200		BURNER COVER LATCH
15	HWP 120008B	BURNER VG400	HWP 2109031		RADIATION SHIELD (UPPER)
16	HWP 2109016	BURNER COVER	HWP 12000		SMOKE FLUE W/RAIN CAP
17	HWP 211153	OIL PREHEAT COIL	HPW 2109033		RADIATION SHIELD (SIDE)
22	HWP 41000	MAIN CONTROL BOX	HWP 2453		REMOTE THERMOSTAT (w/o cord)
23	HWP 2109023	BRACKET, MAIN CONTROL BOX	HWP 100428		GASKET FOR 120008 OR 120008B
24	HWP 26400	MAIN SWITCH	HWP 21724011		FLANGE ADJ. FOR 120008 OR 12008B
25A	HWP 21800	OVERHEAT LIMIT SWITCH(bimetallic)	HWP 62459002		ORIFICE PACK FOR 120008B
25B	HWP 21400**	OVERHEAT LIMIT (CAPILLARY)	HWP 40850SS		SILICONE SEAL - 40850 THERM. BOX
26	HWP 40850	THERMOSTAT BOX	ACC 40SV06		OPTIONAL REGULATOR FOR MORE THAN 14" W.C.
			HWP 210047		RUBBER EDGE SEAL (SOLD PER FOOT) (30 FEET PER HEATER)
			HWP 2109034		WIRE HARNESS
			DKV400		DECAL KIT
			180036		KIT TO CHANGE OVERHEAT LIMIT
			86800		SILICONE SLEEVE (sold in 4ft. sections)

Also see Control Box Parts page 17.

**Note: Overheat limit switch - New design (capillary tube)
S/N M2728-2746, M4769 and greater



WAYNE BURNER PARTS BREAKDOWN

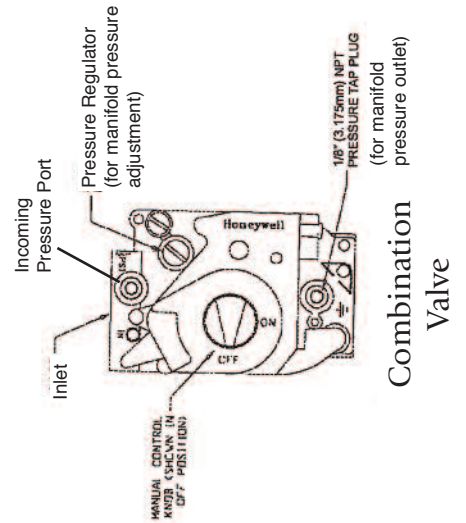
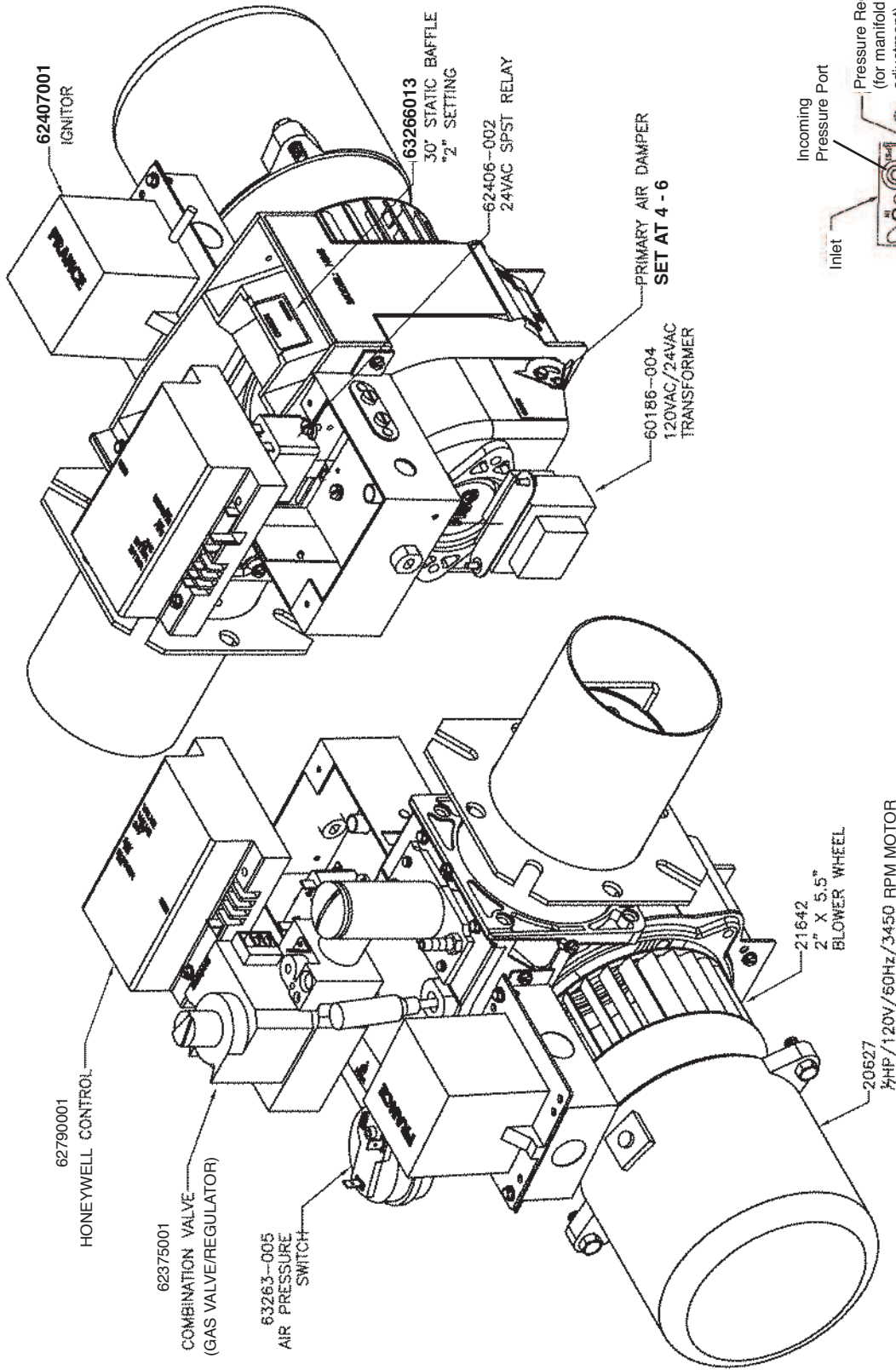

WAYNE BURNER PARTS BREAKDOWN

PART#	DESCRIPTION
1	ELECTRODE
2	ELECTRODE SLEEVES (QTY 2)
3	FLAME SENSOR
4	ORIFICE HOUSING
5	BURNER MANIFOLD
6	ORIFICE CAP
7	ORIFICE CAP GASKET
8	ORIFICE SPRING
9	.332 PROPANE ORIFICE
10	.468 NAT GAS ORIFICE
11	TOP PLATE HOUSING COVER
12	IGNITION WIRE
13	FLAME SENSOR WIRE
14	ELECTRODE BRACKET
15	CLIP-ELECTRODE BRACKET
16	BURNER MANIFOLD

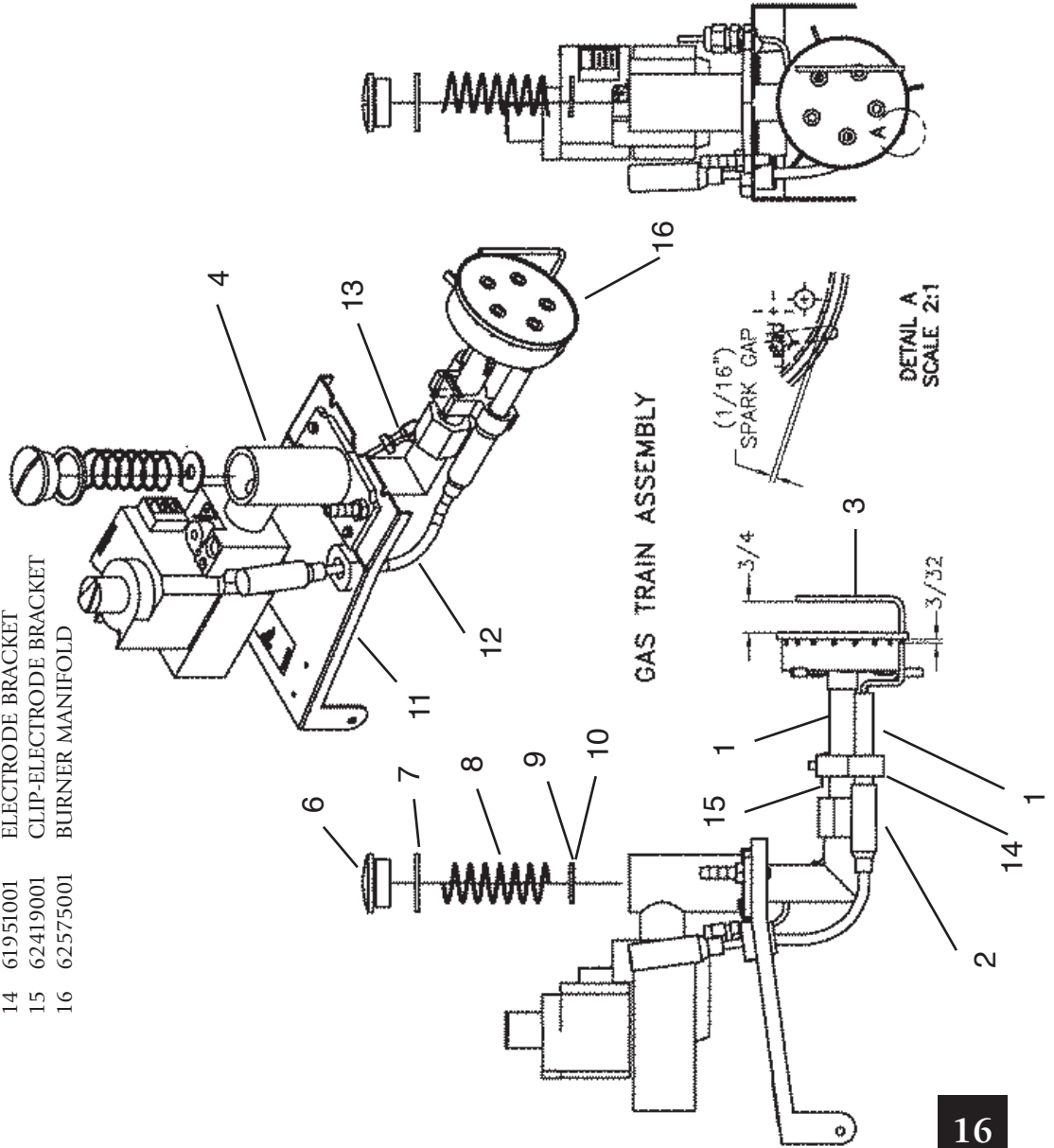

HSG POWER GAS BURNER
WITH HONEYWELL S89F PRIMARY
WIRING DIAGRAMS

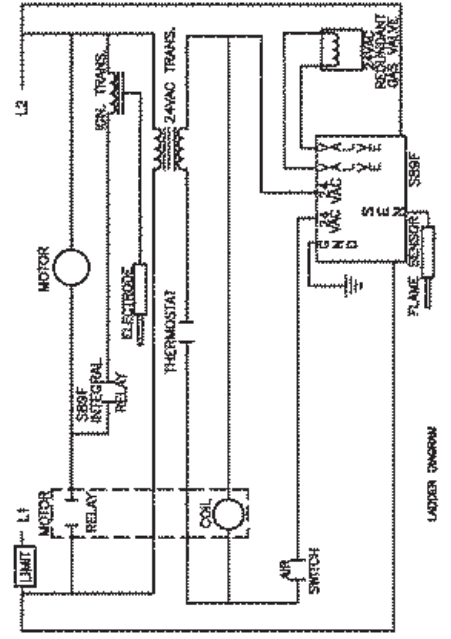
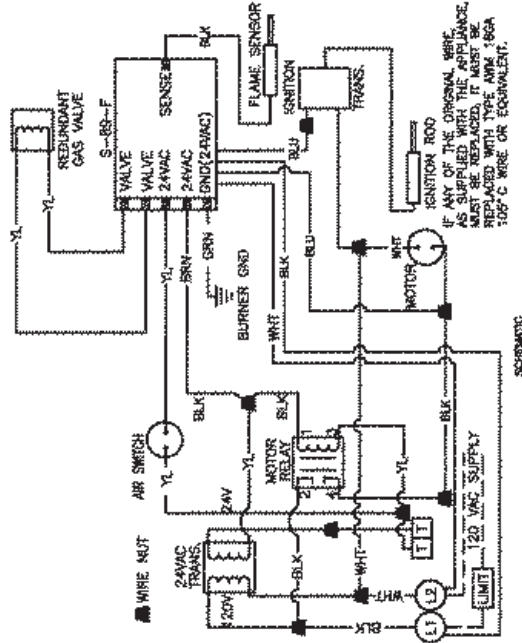

120 Volt 1

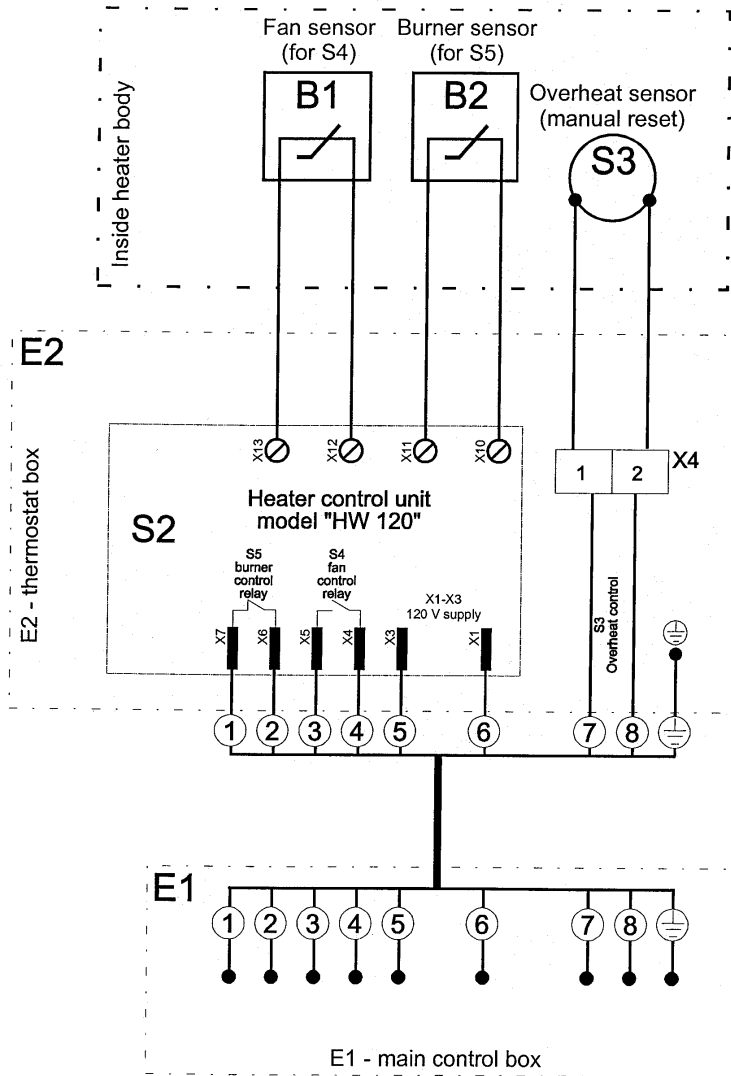

SENSOR RESISTANCE CHART

Degrees Fahrenheit	Degrees Celcius	Resistance (1K Ohm Scale)*	Degrees Fahrenheit	Degrees Celcius	Resistance (1K Ohm Scale)*
-40	-40	330.6	185	85	1.07
-31	-35	239	194	90	0.9156
-22	-30	174.7	203	95	0.7862
-13	-25	129	212	100	0.6777
-4	-20	96.21	221	105	0.5863
5	-15	72.42	230	110	0.5089
14	-10	55.01	239	115	0.4433
23	-5	42.14	248	120	0.3873
32	0	32.55	257	125	0.3395
41	5	25.34	266	130	0.2985
50	10	19.87	275	135	0.2633
59	15	15.7	284	140	0.2328
68	20	12.49	293	145	0.2065
77	25	10	302	150	0.1836
86	30	8.059	311	155	0.1636
95	35	6.534	320	160	0.1455
100	40	5.329	329	165	0.1303
113	45	4.371	338	170	0.1169
122	50	3.604	347	175	0.1052
131	55	2.988	356	180	0.09484
140	60	2.489	365	185	0.08569
149	65	2.084	374	190	0.07757
158	70	1.753	383	195	0.07037
167	75	1.481	392	200	0.06396
176	80	1.256			

* Correct Ohm reading when sensors are at the above listed temperatures



120 Volt 1 PH

BLOWER MOTOR SCHEMATIC

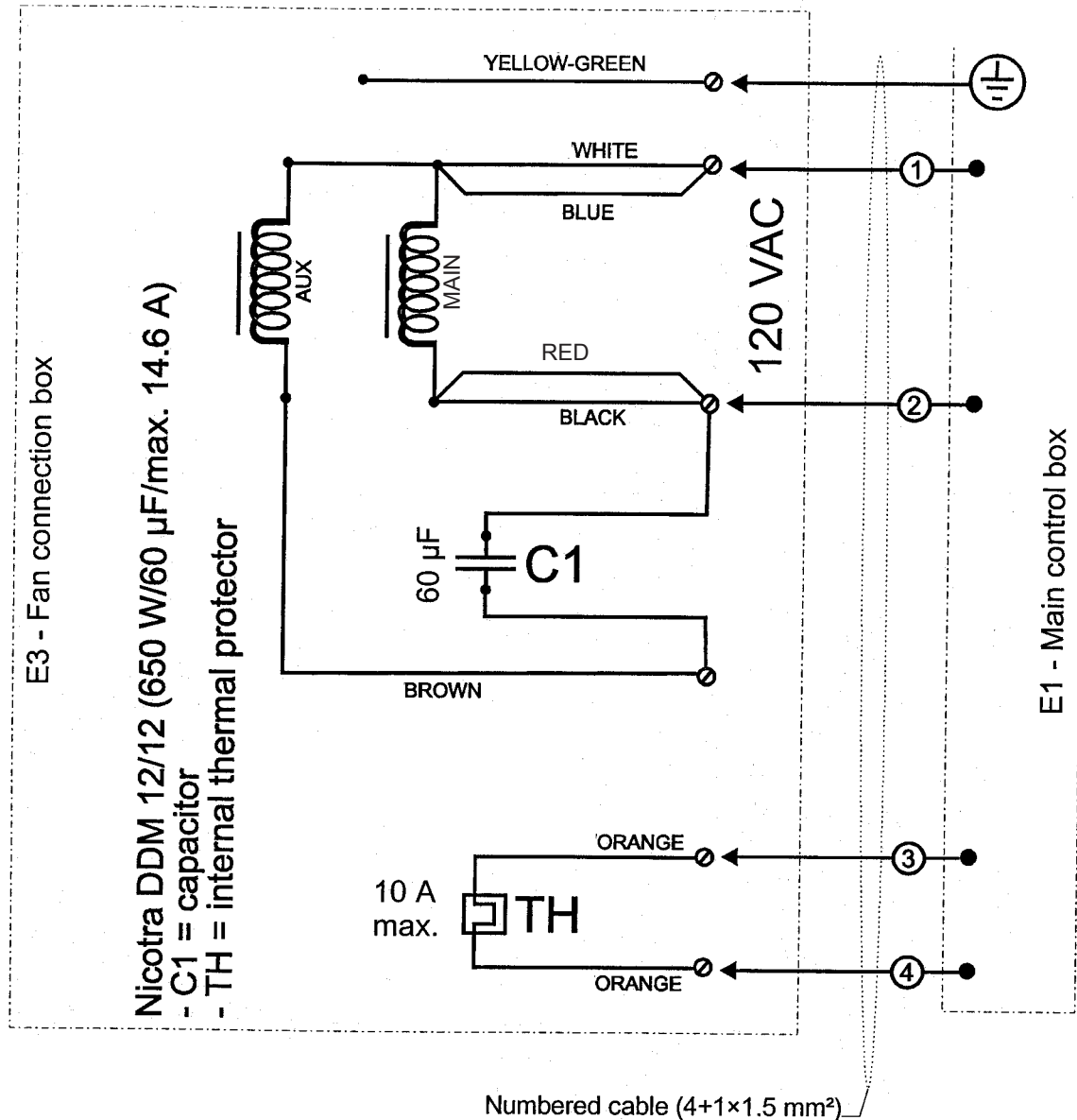

ITEM	PART#	DESCRIPTION
E1	HWP 41000	MAIN CONTROL BOX
E2	HWP 40850	THERMOSTAT BOX
E3	HWP 40900	FAN CONNECTION BOX
S1	HWP 26400	MAIN SWITCH
S2	HWP 20579	HEATER CONTROL UNIT,
B1	HWP 20581	FAN SENSOR (for S4)
B1	HWP 20583	FAN SENSOR 225MM TUBE
B2	HWP 20582	BURNER SENSOR (for S5)
S3	HWP 21800	OVERHEAT LIMIT SWITCH (BIMETALLIC)
	HWP 21400	OVERHEAT LIMIT (CAPILLARY)
X1	HWP 36701	TERMINAL BLOCK (E1)
X2	HWP 36100	GROUNDING BLOCK (E1)
	HC1020	POWER CABLE & PLUG
X4	HWP 36701	TERMINAL BLOCK (E2)
X5	HWP 36701	TERMINAL BLOCK (E3)
CI		CAPACITOR
TH		INTERNAL THERMAL PROTECTOR

120 Volt 1 PH

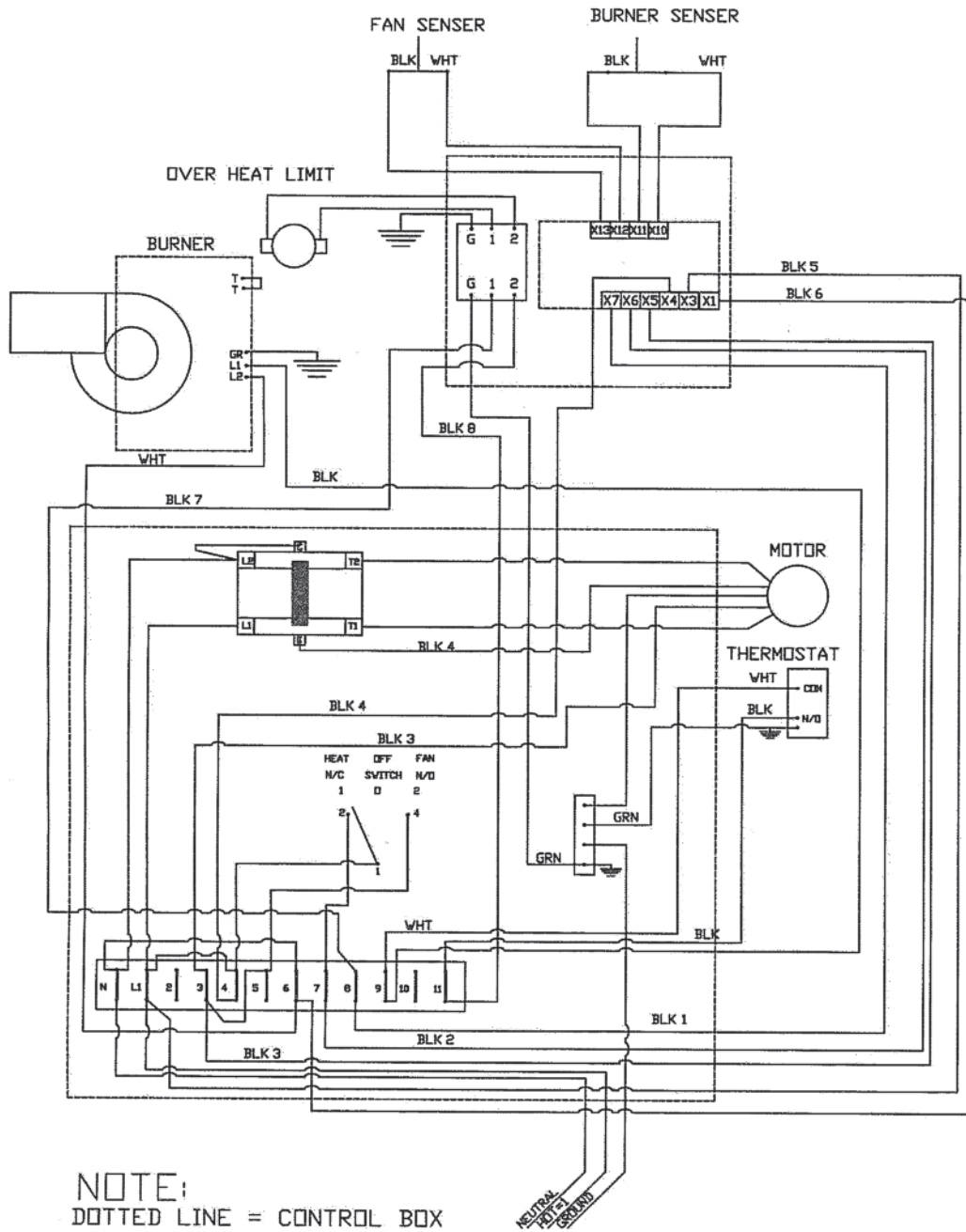

NOTE:
 DOTTED LINE = CONTROL BOX

EXHAUST FLUE PIPE GUIDELINES

CAPACITY OF TYPE B DOUBLE-WALL VENTS SERVING A SINGLE DRAFT HOOD-HEATER x 1000 BTU'S

FOR INDOOR APPLICATIONS

- The flue pipe is to be made of non-combustible material and clearances from combustible materials must be a minimum 8 inches (temperature of flue gases is approximately 410° F).

Flue pipe must be used at all times!
 For flue pipe lengths over 21", you must increase the flue pipe diameter.
 See chart below:

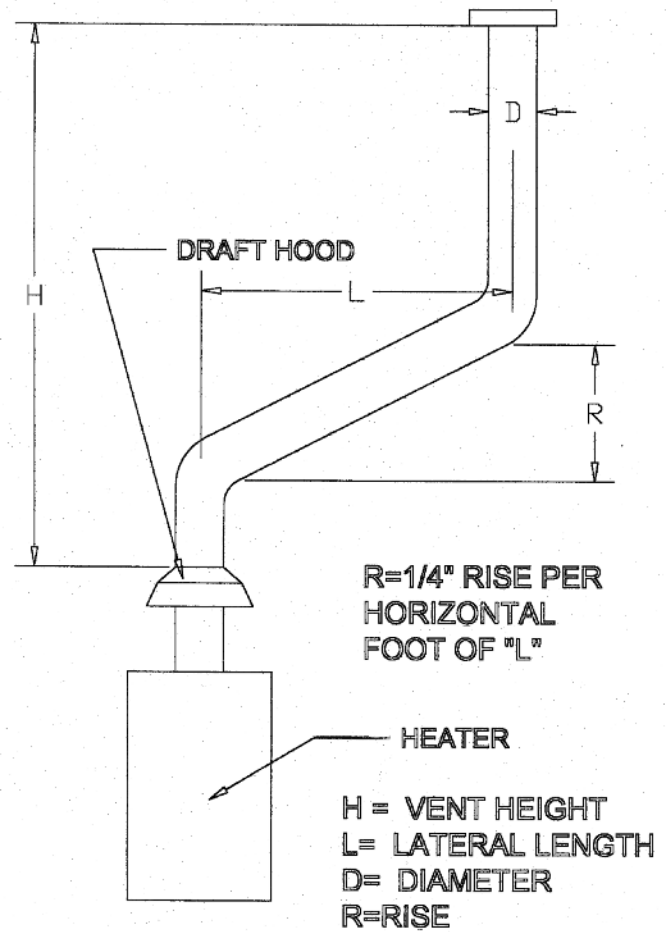

		VENT DIAMETER (D) INCHES			
		8	10	12	14
TOTAL VENT HEIGHT(H) FEET	LATERAL LENGTH (L) FEET				
6	0	370	570	850	1170
	2	285	455	650	890
	6	273	435	630	870
	12	255	406	610	840
8	0	415	660	970	1320
	2	322	515	745	1020
	8	303	490	720	1000
	16	281	458	685	950
10	0	450	720	1060	1450
	2	355	560	850	1130
	10	330	525	795	1080
	20	300	486	735	1030
15	0	525	840	1240	1720
	2	414	675	985	1350
	15	373	610	905	1250
	30	328	553	845	1180
20	0	575	930	1350	1900
	2	470	755	1100	1520
	10	443	710	1045	1460
	20	410	665	990	1390
30	0	380	626	945	1270
	2	380	626	945	1270
	20	650	1060	1550	2170
	40	535	865	1310	1800
	20	473	784	1185	1650
	40	415	705	1075	1520

VAPORIZATION RATES IN BTUH @ 0 DEG. F							
TANK SIZE	NUMBER OF TANKS MANIFOLDED	PERCENTAGE OF TANK FILLED					
		10%	20%	30%	40%	50%	60%
250							
	1	12,690	169,200	197,400	225,600	253,800	282,000
	2	279,180	372,240	434,280	496,320	558,360	620,400
325	3	486,027	648,036	756,042	864,048	972,054	1,080,060
	1	160,650	214,200	249,900	285,600	321,300	357,000
	2	353,430	471,240	549,780	628,320	706,860	785,400
500	3	615,289	820,386	957,117	1,093,848	1,230,579	1,368,842
	1	198,135	264,180	308,212	352,240	396,270	440,300
	2	435,897	581,196	687,066	774,928	871,794	968,660
850	3	758,857	1,011,809	1,180,451	1,349,079	1,517,714	1,686,349
	1	304,425	405,900	473,550	541,200	608,850	676,500
	2	669,735	892,980	1,041,810	1,190,640	1,339,470	1,488,300
1000	3	1,165,947	1,554,597	1,813,696	2,072,796	2,331,895	2,590,995
	1	354,240	472,320	551,040	629,760	708,480	787,200
	2	779,328	1,039,104	1,212,288	1,385,472	1,558,656	1,731,840
	3	1,356,739	1,808,985	2,110,483	2,411,980	2,713,478	3,014,976

NOTE: USE FOLLOWING MULTIPLIERS FOR OTHER AIR TEMPERATURES

- For -10° F multiply x 0.50
- For + 10°F multiply x 1.5
- For +20°F multiply x 2.0
- For +40°F multiply x 3.0
- For +50°F multiply x 3.5
- For +60°F multiply x 4.0

Notes:

We Stock A Complete Line Of Parts & Accessories

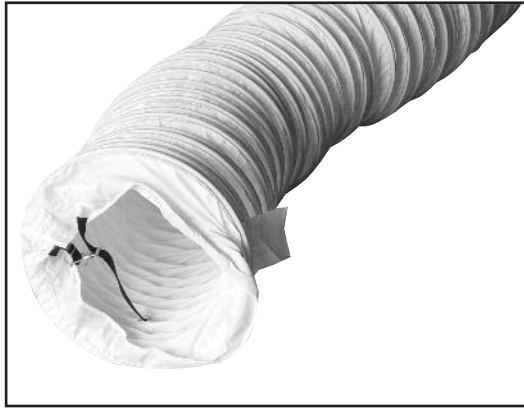

DUCTING

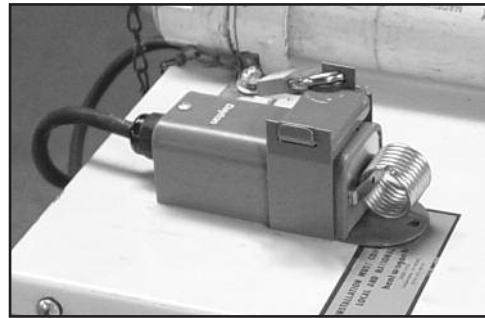

THERMOSTAT
LOCK BOXES



HOSES



REGULATORS



342 N. Co. Rd. 400 East
Valparaiso, IN 46383

219-464-8818 • Fax 219-462-7985

www.heatwagon.com