



342 N. Co. Rd. 400 East
Valparaiso, IN 46383
219-464-8818 • Fax 219-462-7985
www.heatwagon.com

Installation and Maintenance Manual

Please retain this manual for future reference.

VG1000

Construction Heater



City of New York
Dept. of Buildings
29-05-E



Revision 11-13

For your safety: Do not use this heater in a space where gasoline or other liquids having flammable vapors are stored.

IMPORTANT INFORMATION! READ FIRST

The heater is designed for use as a construction heater under ANSI Z83.7a-2000. Heater is not intended for use in pest remediation. The primary purpose of construction heaters is to provide temporary heating of buildings under construction, alteration, or repair and to provide emergency heat. Properly used, the heater provides safe, economical heating. Products of combustion are vented outside the area being heated.

The heater **IS NOT** designed as an Unvented Gas Fired Room Heater under ANSI-Z21.11.2 and **SHOULD NOT** be used in the home.

ANSI A119.2(NFPA 501C)-1987 Recreational Vehicle Standard prohibits the installation or storage of LP-gas containers even temporarily inside any recreational vehicle. The standard also prohibits the use of Unvented Heaters in such vehicles.

NFPA-58 1989 STANDARD FOR THE STORAGE AND HANDLING OF LIQUEFIED PETROLEUM GASES

Use of the heater must be in accordance with this Standard and in compliance with all governing state and local codes. Storage and handling of propane gas and propane cylinders must be in accordance with NFPA 58 and all local governing codes.

We cannot anticipate every use which may be made for our heaters. **CHECK WITH YOUR LOCAL FIRE SAFETY AUTHORITY IF YOU HAVE QUESTIONS ABOUT LOCAL REGULATIONS.**

Other standards govern the use of fuel gases and heat producing products in specific applications. Your local authority can advise you about these.

FOR YOUR SAFETY

DO NOT USE THIS HEATER IN A SPACE WHERE GASOLINE OR OTHER LIQUIDS HAVING FLAMMABLE VAPORS ARE STORED OR USED.

CONSTRUCTION HEATER GENERAL HAZARD WARNING:

Failure to comply with the precautions and instructions provided with this heater, can result in death, serious bodily injury and property loss or damage from hazards of fire, explosion, burn, asphyxiation, carbon monoxide poisoning, and/or electrical shock.

Only persons who can understand and follow the instructions should use or service this heater.

If you need assistance or heater information such as an instruction manual, labels, etc., contact your local Heat Wagon dealer or the manufacturer.

W A R N I N G

Fire, burn, inhalation, and explosion hazard. Keep solid combustibles, such as building materials, paper or cardboard, a safe distance away from the heater as recommended by the instructions. Never use the heater in spaces which do or may contain volatile or airborne combustibles, or products such as gasoline, solvents, paint thinner, dust particles or unknown chemicals.

Not for home or recreational vehicle use!

If you have read this entire manual and you still have questions, please call us at 219-464-8818

Installation and Maintenance Manual

Model VGI000

Construction Heater

Table of Contents:

	Page
Safety & Caution	4
Specifications	4
Operating Instructions	5
Troubleshooting	8
Maintenance	13
Illustrated Parts Breakdown	16
Wiring Diagrams	23
Senso	23
Exhaust Flue Pipe Guidelines	29

WARRANTY

This heater is guaranteed against defective materials and workmanship for one (1) year from Heat Wagon invoice date.

Warranty repairs may be made only by an authorized, trained and certified Heat Wagon dealer. Warranty repairs by other entities will not be considered. Warranty claims must include model number and serial number. Components are guaranteed to the extent of the component manufacturer's warranty.

LIMITATIONS

Warranty claims for service parts (wear parts) such as spark plugs, igniters, and flame rods will not be allowed. Diagnostic parts such as voltage meters and pressure gauges are not warrantable. Evidence of improper fuel usage, fuel pressures outside of manufacturer's specification, poor fuel quality, improper electric power, misapplication and/or evidence of abuse may be cause for rejection of warranty claims.

Labor, travel time, mileage and shipping charges will not be allowed. Minor adjustments to heaters are the responsibility of the dealer. Defective parts must be tagged and held for possible return to the factory for 60 days from date of repair. The factory will provide a return goods authorization, (RGA) for defective parts to be returned. No warranty will be allowed for parts not purchased from Heat Wagon.



342 N. Co. Rd. 400 East • Valparaiso, IN 46383
219-464-8818 • 888-432-8924 • Fax 800-255-7985
www.heatwagon.com

SAFETY & CAUTION

- Instructions given in this manual and the applicable regulation of the local authorities must be followed.
- The unit may be operated only by those persons who have been instructed in its proper use.
- The unit is to be installed and operated in such a way as to ensure the safety of employees and surroundings.
- Never cover the unit's air openings.
- Always ensure adequate fresh air supply to the unit.
- Never stand in front of the discharge end of the heater.
- Keep a minimum clearance of 10 feet from the fuel source. Storing and use of liquid fuel must comply with the regulation and instructions given by the local authorities.
- Unit's emitted noise level at the range of 3 feet: 74 dBA.
- Do not introduce foreign objects into the unit.
- Do not expose the unit to direct water jets.
- All electric cables outside the unit are to be protected against damage.
- Always disconnect the unit from power supply and turn off the gas supply when maintenance or service is being performed.
- **IF NOT OPERATED WITHIN GUIDELINES OF THESE OPERATING INSTRUCTIONS, MANUFACTURER WILL NOT BE HELD RESPONSIBLE AND WARRANTY WILL BECOME VOID.**

SPECIFICATIONS

Model No. VG1000

Fuels:	Vapor Propane or Natural Gas
Gas Inlet	1-1/4" FNPT (Both Wayne & Midco Burner)
Capacity:	1,000,000 BTU/HR
Blower:	4,075 CFM 5.0HP 2.0"SP
Electrical Rating:	240 Volts, 1Ø 30 Amps
Fuel Consumption:	NG-1000 CFH / Propane-11 GPH
Remote Thermostat:	On/Off
Max. Discharge Temp.:	200°F @ 0°F Ambient
Duct Size:	20" Dia., 200 ft. max (straight)
Shp. Dimensions:	120"L x 31.5"W x 54"H
Weight (approximate):	1,300 lbs.

Gas Supply:	Inlet Pressure		Manifold Pressure	Pilot Orifice
	Max W.C.	Min W.C.	W.C.	
Midco Burner				
Vapor Propane	14" W.C.	9" W.C.	2.6"	.046
Natural Gas	14" W.C.	9" W.C.	4.1"	.052
Wayne Burner				
Vapor Propane	14" W.C.	9" W.C.	3.0"	N/A
Natural Gas	14" W.C.	9" W.C.	4.6"	N/A

OPERATING INSTRUCTIONS

INSTALLATION

- When transporting, use all four lifting eyes in upper corners or forklift openings in the base of the units.
- Place the unit on a level and non-combustible surface.
- Minimum clearances from combustibles:
 - outlet, minimum 10 feet
 - sides, minimum 3 feet
 - top, minimum 3 feet
 - flue pipe exhaust, gas discharge minimum 2 feet
- Manufacturer recommends a free zone of 5 feet around the unit and a minimum distance of 10 feet at the unit's flue gas openings are to be maintained.
- If the unit is placed indoors, secure an adequate fresh air opening for the burner combustion air.
- The unit may not be installed and operated in premises where explosive or combustible fumes or dust are present. Always check the regulation of local authorities.
- Be certain that neither the air inlet nor the air outlet is obstructed.

FUEL SUPPLY

- This heater is shipped as either natural gas or vapor propane. Check for proper pilot orifice in burner (Midco burner only).

Natural Gas .052

Vapor Propane .046

- Be certain to use adequate hose or pipe size to ensure proper volume and pressure.

See Chart Below.

NATURAL GAS QUICK REFERENCE HOSE

Hose Length in Feet	BTU 1 Million			
	<1PSI	1PSI	2PSI	5PSI
10	1-1/2	1-1/4	3/4	3/4
25	2	1-1/4	3/4	3/4
35	2	1-1/4	3/4	3/4
50	2	1-1/4	1-1/4	3/4
75	2	1-1/4	1-1/4	3/4
100	2	1-1/4	1-1/4	3/4
125	2-1/2	1-1/2	1-1/4	3/4
150	2-1/2	1-1/2	1-1/4	3/4
175	2-1/2	1-1/2	1-1/4	3/4
200	2-1/2	1-1/2	1-1/4	3/4

VAPOR PROPANE QUICK REFERENCE HOSE

Hose Length in Feet	BTU 1 Million	
	1/2PSI	10PSI
10	1-1/4	3/4
25	1-1/4	3/4
35	1-1/4	3/4
50	-	3/4
75	-	3/4
100	-	3/4
125	-	3/4
150	-	3/4
175	-	3/4
200	-	3/4

For supply pressures greater than 1/2psi

- A regulator must be installed on the heater to ensure that the pressure to the heater does not exceed 1/2 psi inlet pressure. Excessive pressures over 1/2 psi (14" W.C.) will damage controls and void warranty.

FUEL SUPPLY (CONTINUED)

- Ensure that for the surrounding temperature, size and capacity of the propane supply cylinder is adequate to provide the rated Btu/hr input to the heater.
- Visually inspect the hose assembly and ensure that it is protected from traffic, building materials, and contact with hot surfaces. If it is evident that there is excessive abrasion or wear, or the hose is cut, replace it immediately.
- Purge air from line and wait 10 minutes for gas to dissipate.
- After installation, check the hose assembly for gas leaks by applying a water and soap solution to each connection.
- Fuel hose must be UL approved.
- The installation of this heater to a natural gas supply must confirm with all applicable local codes or, in the absence of local codes, with the *National Fuel Gas Code ANSI Z223.1/NFPA 54*. For vapor propane, refer to standard for *Storage and Handling of Liquefied Petroleum Gases ANSI/NFPA 58*.

ELECTRICAL

- Electric cable extensions must be connected by qualified authorized electricians based on the unit capacity and cable length.
- Connect unit to a power supply with a suitable appliance receptacle (30 Amp). Green indicator lamp will light up.
- Confirm voltage at heater connection (208V min.) to ensure proper operation.

EXHAUST FLUE PIPE

- The unit is to be connected to a flue pipe with adequate draft, to ensure the proper start and operation of the unit. Refer to page 27.
- The flue pipe is to be made of non-combustible material and clearances from combustible materials must be a minimum 8 inches (temperature of flue gases is approximately 410° F).
- The flue pipe and its installation must comply with the regulations and instructions given by the local authorities.

START UP

- Only people trained in the operation and supervision of this heater should operate and maintain the unit.
- Check the unit to make certain that there are no visible defects on the control and safety devices and that the unit has been installed correctly.
 1. Open door at back of unit (control box compartment).
 2. Check that the control switch in the control box is in position "0" (STOP).
 3. Pre-select desired room temperature on the room thermostat. The temperature must be set higher than the ambient temperature.
 4. Open all possible shut-off devices of the fuel supply lines and push the reset on the low pressure gas switch (Wayne Burner Only).

START UP (CONTINUED)

5. Turn the control switch in control box to position "1" (HEATING).
 6. When the ambient temperature level is lower than thermostat setting, the burner switches on automatically. The fan does not switch on until the set temperature (104°F) of the heat-exchanger has been reached (will take approximately 1-5 minutes).
 7. The green indicator lamps for "heating on" and "fan on" will light up now.
 8. Close the door in order to protect the unit against unauthorized adjustments.
- After startup, the heater is operated automatically by the room thermostat and governed by all control devices, including the safety limit controls.
 - The room thermostat (TSTAT) and burner sensor control the running sequences of the burner and the fan sensor controls the fan function.
 - Overheat limit reset (STB) controls and shuts off the heater (burner) in the case of overheating.
 - The unit can also be used for ventilation purposes only, if needed.
 1. Turn the control switch in control box to position "2" (VENTILATION).
 2. The unit is now in the continuous ventilating mode.
 3. Heating is not possible in this mode.

DUCTING (Warm Air)

- Minimum clearance from combustibile materials is 4 inches.
- Use steel ducting or fabric ducting capable of withstanding maximum temperature of 300°F.
- Maximum length of duct: 200' (straight).
- Duct diameter: 20".
- Make certain that the duct is safely and properly fastened to the warm air outlet.
- Avoid sharp bends and corners to ensure maximum air flow and avoid back pressure that can cause heat accumulation in heater.
- FAILURE TO COMPLY WITH THESE RECOMMENDATIONS COULD RESULT IN SHUTDOWN OF THE HEATER.

SHUT DOWN

- Turn control switch to position "0" (STOP).
- Close fuel supply.

Important!

The air supply fan continues running for several minutes to cool down the combustion chamber/heat exchanger. The fan can restart several times before finally switching off!

WARNING!

ELECTRICAL POWER TO THE UNIT MAY BE DISCONNECTED IN EMERGENCY SITUATIONS ONLY. OTHERWISE, DO NOT STOP THE UNIT BY DISCONNECTING POWER. UNIT NEEDS TO COOL DOWN USING ITS OWN FAN. FAILURE TO COMPLY WITH PROPER SHUT-DOWN PROCEDURES CAN CAUSE DAMAGE TO THE COMBUSTION CHAMBER, HEAT EXCHANGER, SAFETY FEATURES AND VOID WARRANTY.

VG1000 TROUBLESHOOTING

Symptom

1. Turn the heater to position #1 and nothing happens.

Possible Causes

- Power supply cord
- Burner reset button on the burner flame safeguard control box is engaged
- Overheat limit switch is tripped
- Burner motor relay
- Burner sensor
- Heater control unit (HCU)

Possible Solutions

- Test for 240 volts (min 208) between L1 and L2 on the main terminal block.
- Reset the blue button on the flame safeguard control.
- Reset the switch, which is located in the burner compartment on the gray box on the left hand side of the burner.
- Burner motor relay is located in the main control box (K2). Check between ground and L1, then ground and T1 for 120 volts. If less than 105 volts replace relay.
- On the heater control unit (HCU) disconnect the wires from terminals X10 and X11. Using an ohm meter, check the resistance between the two wires for a reading. Compare to Sensor Resistance Chart page 25. Replace sensor if reading is out of range.
- On the main terminal block, check for 120 volts between terminals 8 and N when the 3-position switch is in the HEAT position. If less than 105 volts, replace HCU.

2. The heater runs for a little while, but shuts down. It won't come on again until the limit switch is reset.

- Incorrect burner manifold pressure

- (Midco Burner) Use a low pressure gauge (0-15 inches of water column) with a 1/4" NPT inlet. Install gauge in the pressure tap port located on the output side of the last gas solenoid valve in line. Run unit and adjust the manifold pressure by turning the pressure adjusting screw (located in the center of the Maxitrol RV81 regulator) in or out until the gauge reads 2.6 inches of W.C. for propane or 4.1 inches of W.C. for natural gas. (Wayne Burner) 3 inches of W.C. for propane or 3.5 inches of W.C. for natural gas.
- Check for dirt or ice buildup on the air inlet or blower wheel. If using duct on the air outlet, ensure the back pressure does not exceed a static pressure of .2" W.C. Check with magnehelic gauge if necessary.
- Adhere to the proper shut down procedures. Power must remain at the unit until it cools down fully. Blower will shut down on its own when cool. Test overheat limit switch for continuity between the two male terminals at room temperature. Replace if overheat limit switch fails test. The limit switch is located in the upper left hand corner of burner compartment.

VG1000 TROUBLESHOOTING

Symptom

3. Burner motor comes on, but the heater won't ignite.

Possible Causes

- Fuel pressure or volume
- Air inlet damper adjustment
- Ignition electrode
- Electronic igniter
- Burner airflow switch
- Gas valve

Possible Solutions

- Use a low pressure gauge (0-15 inches of water column) with 1/8" NPT inlet. Install gauge in the pressure tap port located on the output side of the gas valve. Run the heater. Adjust the pressure by turning the pressure adjusting screw (located on the input side top of the gas valve) counter clockwise until the gauge reads the proper manifold pressure. Refer to pipe sizing charts in the Heat Wagon Engineering Guide. Heater requires 9-14" W.C. inlet pressure. Ensure proper purge procedure (see Fuel Supply Installation).
- Rough setting at 1/2 open. Minor adjustments from the rough settings can be made to achieve a smooth sounding burner with no soot from the flue pipe. Insert volt meter probes into provided + and - terminals on the Honeywell Flame Safeguard Control. Set the volt meter on DC volts and run the heater. Adjust the air damper until the volt meter reads the highest voltage between 2 and 5 volts.
- Clean with fine sandpaper. Make sure it is free from buildup or cracks.
- Turn off the gas valve, turn on the burner. Use insulated pliers to hold the ignition wire and short it to ground. Pull the wire away from ground slowly. A rainbow colored arc should travel between the wire and the ground at a distance of 3/8 of an inch for a duration of 4-5 seconds.
- The burner airflow switch (located above blue Honeywell safeguard control) will not allow power to the flame safeguard control when it is open. Check the tubes supplying air to the switch for any restrictions. ONLY AS A TEST, wire around the air switch. If this test solves the problem, adjust or replace the switch (Midco Burner Only).
- If there is power at the flame safeguard control and no power out to the solenoid valves, replace the flame safeguard control. Check for continuity between the terminals on the solenoid valve coil. If no continuity, replace gas valve.

VG1000 TROUBLESHOOTING**Symptom****Possible Causes**

4. The heater has a loud rumbling sound.
- Air damper setting
 - Dirt on burner blower wheel
 - Flue pipe setup or flue pipe restrictions
 - Gas manifold pressure
 - Heat exchanger

Possible Solutions

- Rough setting at 1/2 open. Minor adjustments from the rough settings can be made to achieve a smooth sounding burner with no soot from the flue pipe. Insert volt meter probes into provided + and – terminals on the Honeywell Flame Safeguard Control. Set the volt meter on DC volts and run the heater. Adjust the air damper until the volt meter reads the highest voltage between 2 and 5 volts.
 - Clean the burner blower wheel with a small brush
 - Refer to the flue pipe chart in this manual. Check flue for restriction
 - Use a low pressure gauge (0-15 inches of water column) with 1/8" NPT inlet. Install gauge in the pressure tap port located on the output side of the gas valve. Run the heater. Adjust the pressure by turning the pressure adjusting screw (located on the input side top of the gas valve) counter clockwise until the gauge reads the proper manifold pressure. Refer to pipe sizing charts in the Heat Wagon Engineering Guide. Heater requires 9-14" W.C. inlet pressure.
 - Refer to the cleaning instructions in this manual.
-
5. The heater blows black smoke out of the vent stack.
- Air damper setting
 - Dirt on burner blower wheel
 - Flue pipe setup or flue pipe restrictions
 - Gas manifold pressure
 - Heat exchanger
- Rough setting at 1/2 open. Minor adjustments from the rough settings can be made to achieve a smooth sounding burner with no soot from the flue pipe. Insert volt meter probes into provided + and – terminals on the Honeywell Flame Safeguard Control. Set the volt meter on DC volts and run the heater. Adjust the air damper until the volt meter reads the highest voltage between 2 and 5 volts.
 - Clean the burner blower wheel with a small brush
 - Refer to the flue pipe chart in this manual. Check flue for restriction
 - Use a low pressure gauge (0-15 inches of water column) with 1/8" NPT inlet. Install gauge in the pressure tap port located on the output side of the gas valve. Run the heater. Adjust the pressure by turning the pressure adjusting screw (located on the input side top of the gas valve) counter clockwise until the gauge reads the proper manifold pressure. Refer to pipe sizing charts in the Heat Wagon Engineering Guide. Heater requires 9-14" W.C. inlet pressure.
 - Refer to the cleaning instructions in this manual.

VG1000 TROUBLESHOOTING

Symptom

6. The burner seems to cycle on and off more frequently than what it should.

Possible Causes

- Gas manifold pressure
- Dirt on main air blower or setup of outlet air duct
- Burner sensor
- Heater Control Unit (HCU)

Possible Solutions

- Use a low pressure gauge (0-15 inches of water column) with 1/8" NPT inlet. Install gauge in the pressure tap port located on the output side of the gas valve. Run the heater. Adjust the pressure by turning the pressure adjusting screw (located on the input side top of the gas valve) counter clockwise until the gauge reads the proper manifold pressure. Refer to pipe sizing charts in the Heat Wagon Engineering Guide. Heater requires 9-14" W.C. inlet pressure.
 - Check for dirt or ice buildup on the air inlet or blower wheel. If using duct on the air outlet, ensure the back pressure does not exceed a static pressure of .5" W.C.
 - On the heater control unit (HCU) disconnect the wires from terminals X10 and X11. Using an ohm meter, check the resistance between the two wires for a reading. Compare to Sensor Resistance Chart page 25. Replace sensor if reading out of range.
 - If all of the above check good, replace the HCU.
-
7. The burner starts, but the main fan never comes on.
- Fan sensor
 - Heater Control Unit (HCU)
 - Blower motor relay
 - Current overload on blower motor
 - Blower motor
- On the heater control unit (HCU) disconnect the wires from terminals X12 and X13. Using an ohm meter, check the resistance between the two wires for a reading. Compare to Sensor Resistance Chart page 25.
 - Turn the 3-position main switch to the fan position. If the blower runs, check the fan sensor. If it is good, replace the HCU.
 - Turn the 3-position main switch to the fan position. If the relay pulls in, check for voltage between the L1 and L2 terminals. Then check the voltage between terminals T1 and T2. The voltage should be the same. If it is less than 105 volts, replace the relay.
 - Push the reset button on the overload between terminals A1 and A2 on the motor relay. If there is no voltage, replace the overload.
 - Turn the 3-position main switch to the fan position. Check for voltage between terminals T1 and T2 on the motor relay. If the voltage checks at 120 volts, replace the motor.

8. The burner continues to run, but the fan cycles on and off.

- Gas manifold pressure
 - Fuel supply pressure and volume
 - Fan sensor
 - Heater Control Unit (HCU)
- Possible Solutions**
- Use a low pressure gauge (0-15 inches of water column) with 1/8" NPT inlet. Install gauge in the pressure tap port located on the output side of the gas valve. Run the heater. Adjust the pressure by turning the pressure adjusting screw (located on the input side top of the gas valve) counter clockwise until the gauge reads the proper manifold pressure. Refer to pipe sizing charts in the Heat Wagon Engineering Guide. Heater requires 9-14" W.C. inlet pressure.
 - Use a low pressure gauge (0-15 inches of water column) with 1/8" NPT inlet. Install gauge in the pressure tap port located on the output side of the gas valve. Run the heater. Adjust the pressure by turning the pressure adjusting screw (located on the input side top of the gas valve) counter clockwise until the gauge reads the proper manifold pressure. Refer to pipe sizing charts in the Heat Wagon Engineering Guide. Heater requires 9-14" W.C. inlet pressure.
 - On the heater control unit (HCU) disconnect the wires from terminals X12 and X13. Using an ohm meter, check the resistance between the two wires for a reading. Compare to Sensor Resistance Chart page 25. If the test falls out of this range, replace fan sensor.
 - Turn the 3-position main switch to the fan position. If the blower runs, check the fan sensor. If it is good, replace the HCU.

MAINTENANCE

Prior to starting any maintenance work be sure to disconnect unit from power supply until unit cools down fully and fan shuts off! (Shut Down Procedures page 7)

To ensure the proper function of the unit, it must be serviced on regular basis. Maintenance can be performed, excluding the control devices and safety limit controls, by an authorized trained & certified Heat Wagon dealer. The control devices and safety limit controls do not need routine maintenance. If these items fail they must be replaced.

- Do not use any aggressive cleaning agents, which are harmful or environmentally unfriendly, when cleaning the unit.
- Do not use water jet when cleaning the unit.
- Pressurized air may be used for maintenance. Be careful not to damage the fan blower wheel with too much pressure.
- - Check whether the unit is free from mechanical damage, replace faulty parts as necessary.
- Check fan blower wheel of the fan at regular intervals and clean it when needed.
- Check functionality of control and safety devices regularly.
- Have the flue gas values of the burner checked regularly by authorized agents.
- Be sure to store the unit in a dust free and dry place when it is not used for a long period of time. Cover the exhaust flue to prevent entry of foreign objects.

SERVICE

- The complete unit, including heat exchanger, combustion chamber and burner should be cleaned from dust and dirt after every heating period, at a minimum of once per year.

-Removal of combustion chamber:

For proper cleaning of the unit, manufacturer recommends removal of the complete combustion chamber with heat exchanger.

-Disassembling of burner:

1. Disassemble four tightening bolts on the combustion chamber flange and remove burner's mounting flange. Take care not to damage the flange seal.
2. Pull out the burner. Take care not to damage the burner head and power cable.

Next step:

1. Pull off collar (1) from flue gas adapter after having removed the fixing screws.
2. Disassemble flue gas adapter (2) from combustion chamber and pull it off.
3. Disassemble center side panel (3) and insulation (4).
Manufacturer recommends removing the left center side panel (seen from the control box end).
4. Disassemble tightening bolts at supports of combustion chamber (5) and pull out combustion chamber sideways.

Important! Take care not to bend or damage supports of combustion chamber!

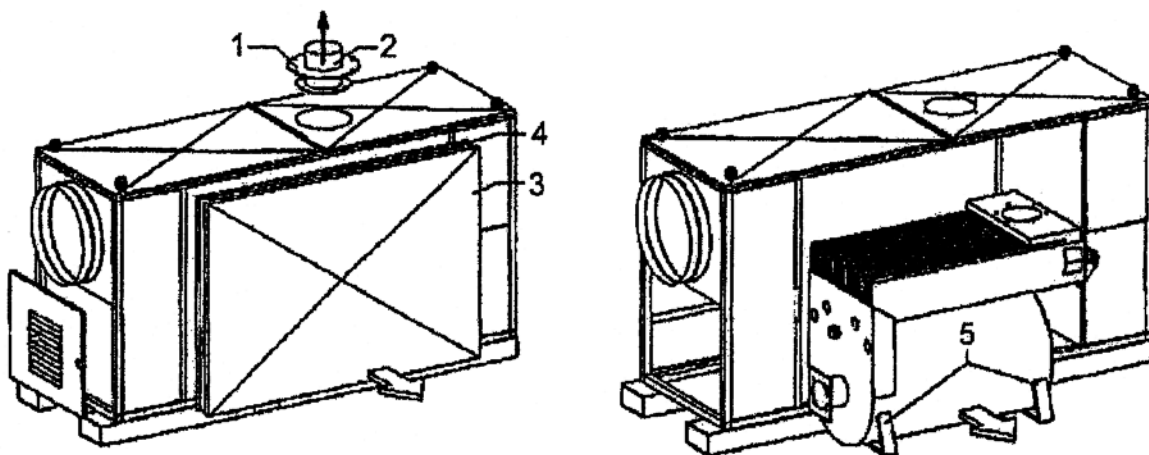

-Heat exchanger

When cleaning the heat exchanger:

1. Disassemble revision cover of heat exchanger (1).
2. Be careful not to tear or damage gasket.
3. Pull all flue gas suppressors (5) (all 15 pcs) out from flue gas passages. Do not bend them.
4. Clean all flue gas passages (6) with a brush or vacuum cleaner.
5. Clean flue gas suppressors or replace them, as necessary.
6. Check gasket of revision cover and replace, as necessary.

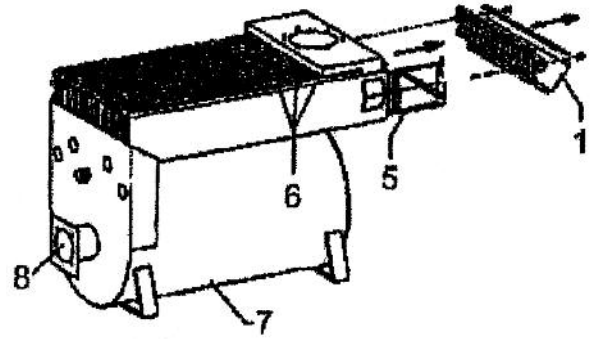

-Combustion chamber

When cleaning the combustion chamber:

1. Clean combustion chamber (7) through its opening (8) with a vacuum cleaner.

-Burner

When servicing the burner:

1. Read the operating and maintenance instructions of the gas burner.
2. Make sure that the burner is exclusively maintained by authorized agents.

-Re-assembly of the unit.

-Heat exchanger:

1. Replace all removed parts in reverse order.
2. Make sure that the gaskets and the revision cover (1) are correctly seated.

-Combustion chamber and burner:

1. Carefully assemble combustion chamber into unit and adjust it. Hand tighten bolts (final tightening after installing the burner's mounting flange).
2. Install burner's mounting flange.
3. Check flange gasket and replace, if necessary.
4. Tighten the screws of combustion chamber supports.
5. Remount all trim panels.
6. Remount flue gas adapter, check gaskets and replace, if necessary.
7. Install burner to the mounting flange. Take care not to damage the burner head and power cable.
8. Re-install all connections and joints and check them thoroughly.
9. Put unit into service and check proper function of all operating modes.
10. Adjust the burner, if necessary.

Important!

An operation or use other than that indicated in these instructions is prohibited!

**VG1000
PARTS
BREAKDOWN**

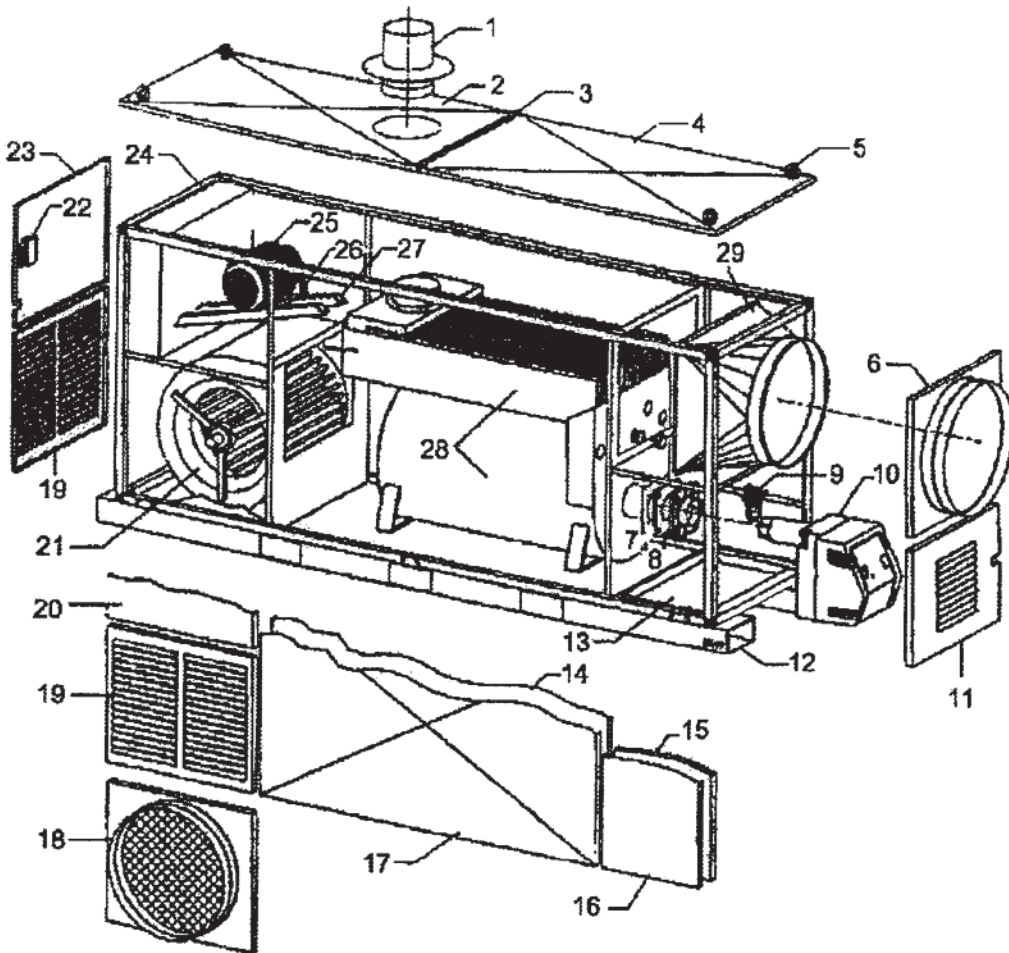

ITEM	PART#	DESCRIPTION	ITEM	PART#	DESCRIPTION
1	HWP 214401	Flue Gas Adapter	23	HWP 214423	Control Compartment Door
2	HWP 214402	Cover Plate, Rear	24	HWP 214424	Main Control Box
3	HWP 214403	Connecting Profile	25	HWP SM6162	Fan Motor
4	HWP 214404	Cover Plate, Front	26	HWP A68	V-Belt (2 Required)
5	HWP 214405	Crane Eye (4)	27	HWP 214427	Guide Rail (2 Required)
6	HWP 214406	Air Outlet Adapter	28	HWP 214428	Combustion Chamber & Heat Exchanger
7	HWP 20529	Flange Seal	29	HWP 214429	Air Outlet Cone
8	HWP 20471	Oil Burner Flange			
9	HWP 110121	Fuel Filter			
10	HWP 110008	Oil Burner			
	HWP 110008B	Gas Burner	Not Shown		
11	HWP 214411	Burner Compartment Door		HWP 214430	Top Radiation Shield
12	HWP 214412	Base		HWP 214432	Revision Cover
13	HWP 214413	Oil Collector		HWP 214433	Gasket for Revision Cover
14	HWP 214414	Insulation, Center (left/right)		HWP 214434	Flue Gas Suppressors
15	HWP 214415	Insulation, Burner End (left/right)		HWP 214435	Drive Pulley, Fan
16	HWP 214416	Side Panel, Burner End (2, with louvres)		HWP 214450	Centrifical Clutch/Motor Sheave
17	HWP 214417	Side Panel, Center (left/right)		HWP 214501	11-3/8" Fan Sheave
18	HWP 214418	Air Inlet Adapter (1, left/right/right options)		HWP 214502	Sheave Bushing Fan
19	HWP 214419	Louvre Panel, Fan End (2, left/right/right options)		HWP 3070	Heat Wagon Logo Decal
20	HWP 214420	Upper Side Panel, Fan End (2)		HWP 214490	Smoke Flue w/Raincap
21	HWP 214421	Radial Fan		HWP 842920	Cover for Honeywell Flame Safeguard Control
22	HWP 214422	Door Belt		HWP 86250F	Fiberglass Gasket Material
				HWP 20529	Burner Gasket

Also see Control Box Parts page 28.

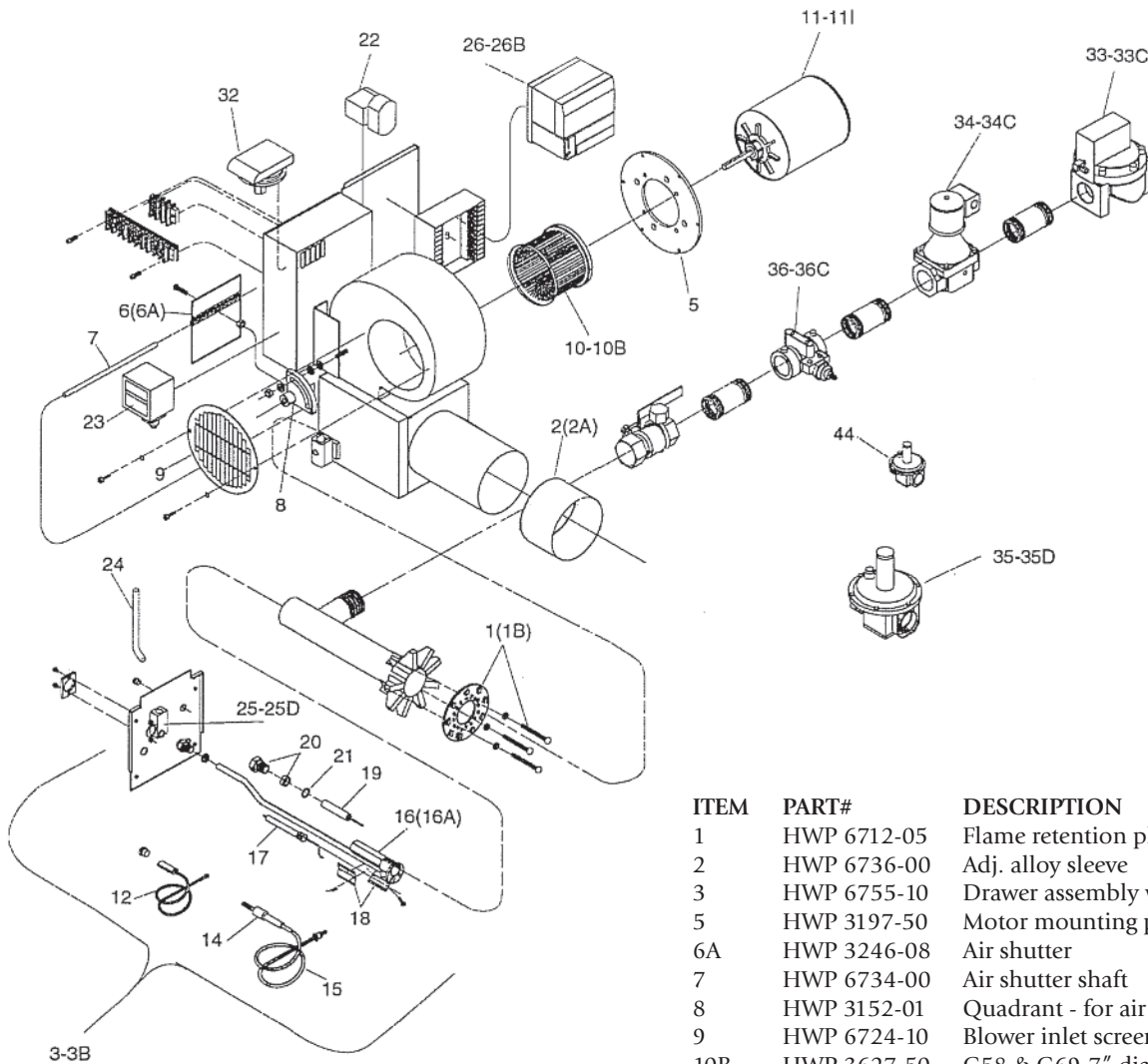

**MIDCO BURNER
PARTS BREAKDOWN**

ITEM	PART#	DESCRIPTION
1	HWP 6712-05	Flame retention plate with mounting
2	HWP 6736-00	Adj. alloy sleeve
3	HWP 6755-10	Drawer assembly with pilot and vent tube
5	HWP 3197-50	Motor mounting plate
6A	HWP 3246-08	Air shutter
7	HWP 6734-00	Air shutter shaft
8	HWP 3152-01	Quadrant - for air shutter adjustment
9	HWP 6724-10	Blower inlet screen
10B	HWP 3627-50	G58 & G69-7" diameter x 3-1/2" wide
11B	HWP 8437-15	G58-1/2 HP 115/230/1/60
12	HWP 6717-90	Flamerod wire replacement kit
13	HWP 5616-90	Strain relief bushing for spark cable
14	HWP 8409-10	Silicone boot
15	HWP 8502-05	Spark cable
16	HWP 6725-90	Pilot with flamerod and spark rod
17	HWP 6717-00	Flamerod and insulator assembly
18	HWP 6720-90	Mounting clamp for flamerod assembly
19	HWP 6725-50	Spark rod and insulator assembly
20	HWP 6764-00	Spark rod retainer assembly w/O-ring seal
21	HWP 8432-07	Spark rod retainer O-ring
22	HWP 8402-00	Gas safety shut-off valve - 1/8" NPT
23	HWP 8447-22	Ignition trans 120/1/60
24	HWP 6729-91	Pilot air tube blower housing
25C	HWP 6766-02	Nat. G58 gas #55 Dr. (.052), air #26 Dr. (.147)
25G	HWP 6766-07	Prop G58 gas #56 Dr. (.046), air #26 Dr. (.147)
26	HWP 8429-19	RM7895A Controller
27	HWP 8429-22	ST7800 for RM7895 30 seconds
28	HWP 8429-27	R7847A for RM7895 rectification amplifier
30	HWP 8429-16	O7800 sub-base
32	HWP 8425-19	Blower air switch
33	HWP 8418-21	1" diaphragm valve
34	HWP 8402-06	1-1/4" safety valve
35A	HWP 8416-02	RV61 1-1/4" Maxitrol gas pressure regulator
36	HWP 2933-50	On/off butterfly valve
44	HWP 8400-10	Pilot pressure regulator

Not Shown

HWP HV1169

Gauge 15" W.C. Low Pressure (2)



WAYNE BURNER
PARTS BREAKDOWN

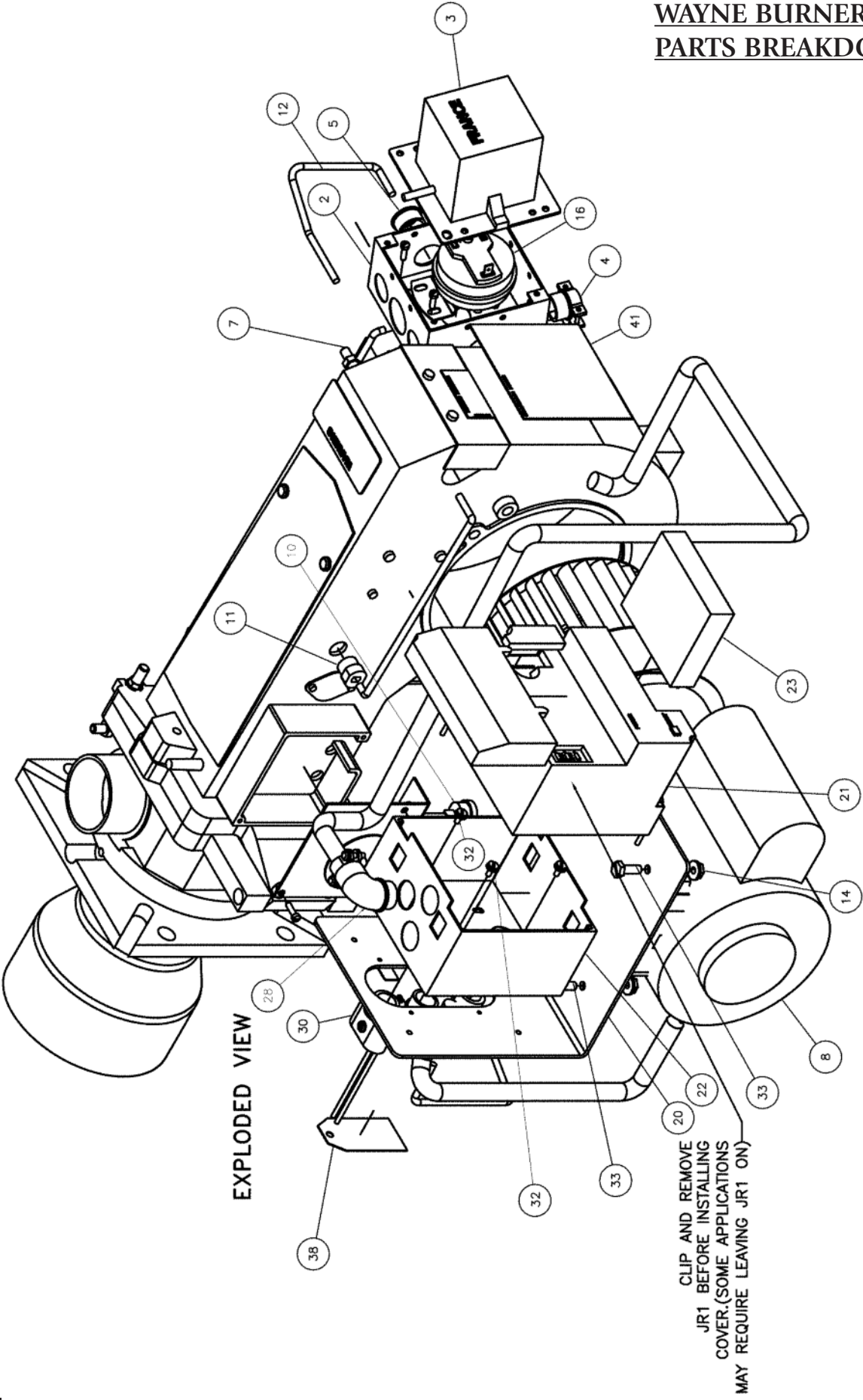

WAYNE BURNER PARTS BREAKDOWN

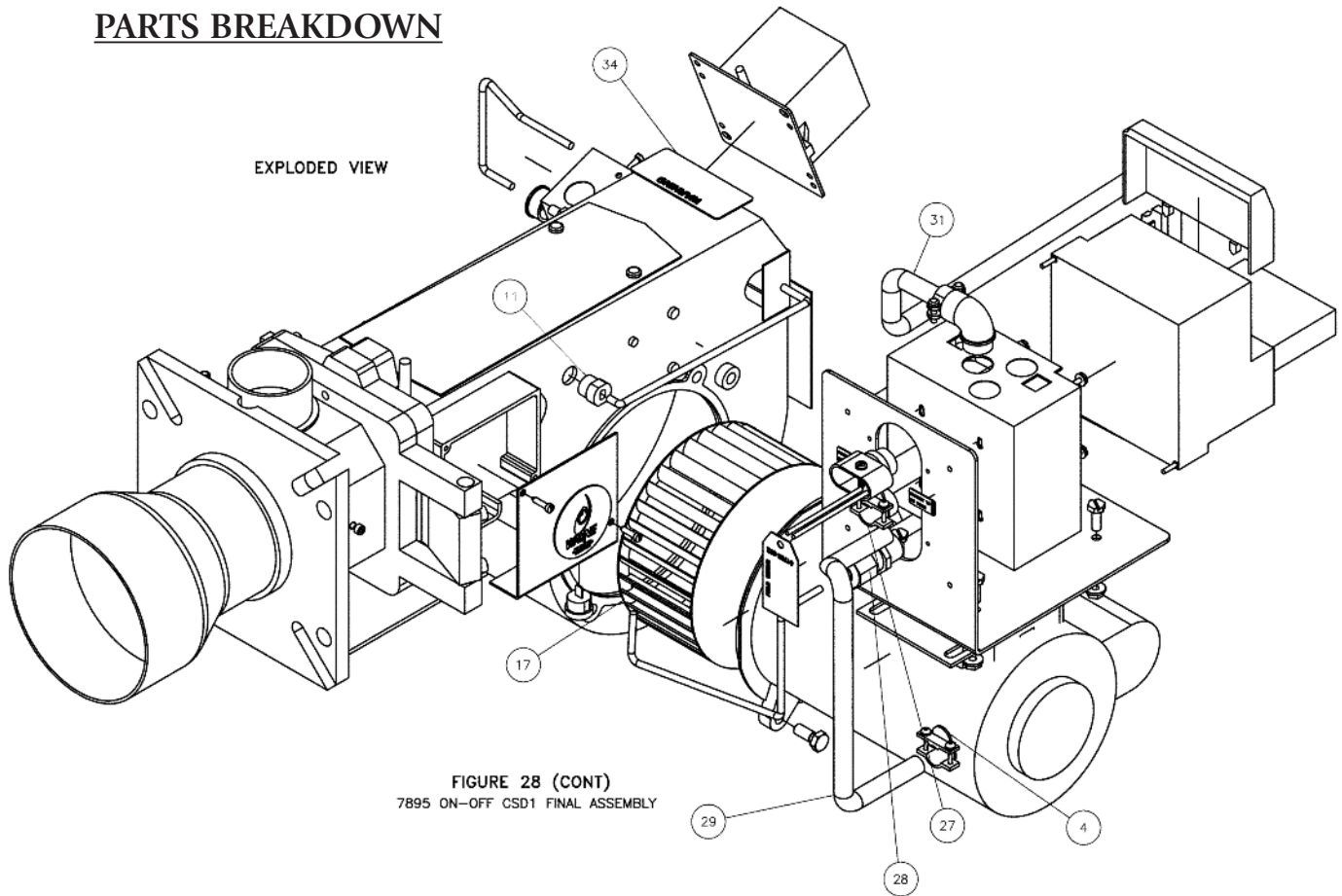

ITEM	PART#	DESCRIPTION	ITEM	PART#	DESCRIPTION
1	63587-001	Housing LC1000 Base Burner	23	63773-XXX (See Bom)	Amplifier, Flame
2	20370-004	Box, Junction Deep Mach	24	63774-XXX (See Bom)	Timer, Purge
3	62407-001	Igniter, Transformer 120V	25	63497-003	Wire, Control Sense
4	13801	Fitting, Conduit 3/8	26	31954-001	Strain Relief, Low Profile
5	13034	Bushing, Snap	27	13801-002	Fitting, Conduit
6	63747-001	Fitting, Adapter	28	15323	Connector, Conduit
7	550052	Fitting, Hose	29	100196-019	Conduit, Flex 3/8" x 12
8	63599-001	Motor, 1/2HP 120V	30	14429	Connector, Conduit Duplex
9	63593-001	Plate, Sense Bushing	31	100196-016	Conduit, Flex 3/8" x 19.50
10	62389-002	Bushing, Terminal	32	15731	Screw, 6-32 Hexslt
11	13026	Bushing, Strain Relief	33	18001	Screw, 1/4-20 x .75
12	100985-003	Tube, Clear Vinyl 1/4 x 9.5	34	62960-001	Decal, Carbon Dioxide Warning
13	62909-004	Wire, Ignition	35	63538-001	Decal, Pressure Regulator
14	100408-002	Nut, Lock 1/4 - 20 HXSR	36	100010	Decal, Wayne Logo
15	63743-001	Wire, Sense Electrode (not shown)	37	101267-001	Decal, Wayne Logo
16	63263-005	Switch, Air Sensing	38	61756-002	Tag, Wiring Supply
17	LC1000 WHEEL	Blower Wheel	39	63528-003	Decal, Connect To Gas Train
20	63769-001	Bracket, Control Mounting "L"	40	63528-004	Decal, Connect to 120V
21	63770-XXX (See Bom)	Primary Control	41	63748-XXX (See Bom)	Decal, Rating
22	63771-001	Wiring Subbase	42	63749-001	Decal, Nighthawk

Not Shown

HWP HV1169	Gauge 15" W.C. Low Pressure (2)
63804-001	Electrode
63805-001	Flame Sensor

WAYNE BURNER SERVICING

Caution: Make sure that the main manual gas valves and main electrical power disconnect are turned off before opening burner or removing any parts for service. All cover plates, enclosures, and guards must be in place at all times, except during maintenance and servicing.

A. BURNER HEAD AND ELECTRODE/SENSOR ASSEMBLY

The burner head, electrodes, and manifold pipe are part of the gas pipetrain assembly. (See Figure 21) To remove the burner head assembly, follow the procedure outlined below:

- Disconnect the union fitting closest to the burner in the gas pipetrain.
- Remove the four allen head screws that hold the manifold pipe to the burner housing.
- Remove the retaining nut that holds the hinged flange together and swing the fan housing slightly to the side. It may be necessary to disconnect the electrical supply to the control panel (if mounted on the burner). Before doing so, make sure the electrical supply is off.
- Disconnect the ignition wire from the electrode and the sensing wire from the flame rod. Swing the fan housing to the side.
- Remove the allen screw that holds the head adjustment knob in place. Remove the knob.
- Remove the screw on the left side of the burner head assembly and pull the head assembly out of the burner.

When servicing, clean burner head ports, electrodes and sensor probe. Inspect the sensor probe and electrode wires and porcelain insulators carefully for hairline cracks, which might provide an electrical leak path that could short out the ignition spark, or flame signal.

Examine the electrode and sensor probe for any serious corrosion or deterioration of metal at the tips. Check for proper dimensional settings of the sensor probe and electrode. Adjust and/or replace these assemblies as necessary. Make sure that the ignition and sensor probe wires go to the correct electrodes and the ignition wire boot is in place over the electrode porcelain.

Make sure that the burner tube end is properly positioned in the combustion chamber entry. It must be set 1/2" (12.7mm) short of the inside face of the combustion chamber as shown in figures 3, 4 or 5.

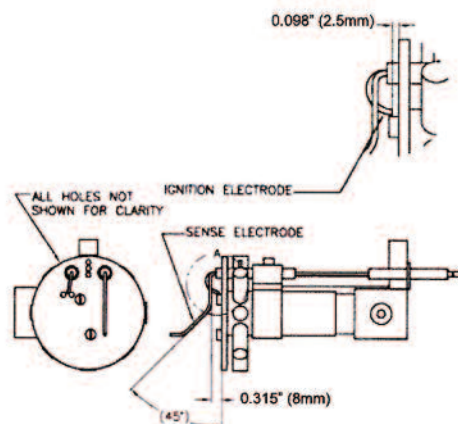

**ELECTRODE
SETTING**

WAYNE BURNER SERVICING

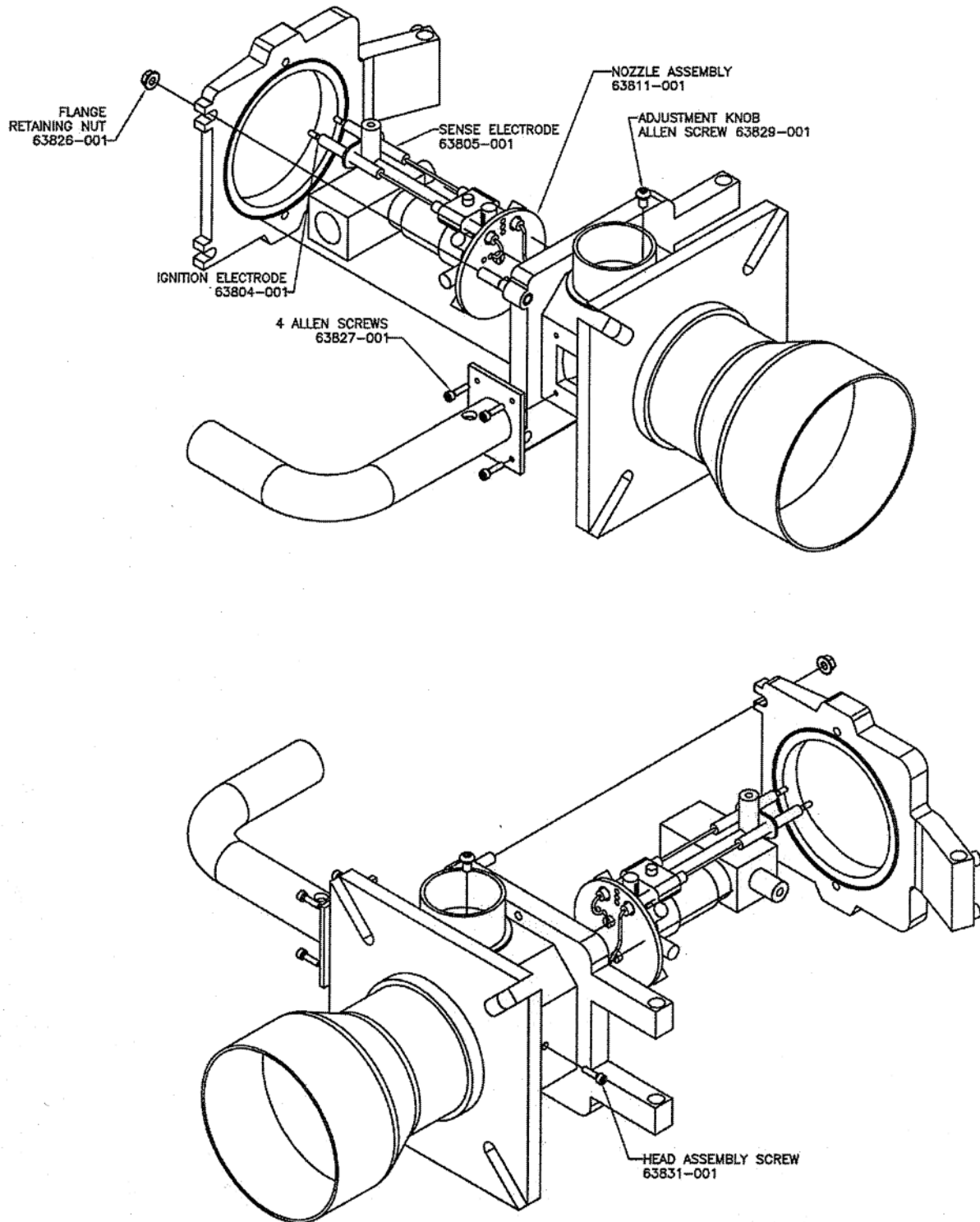
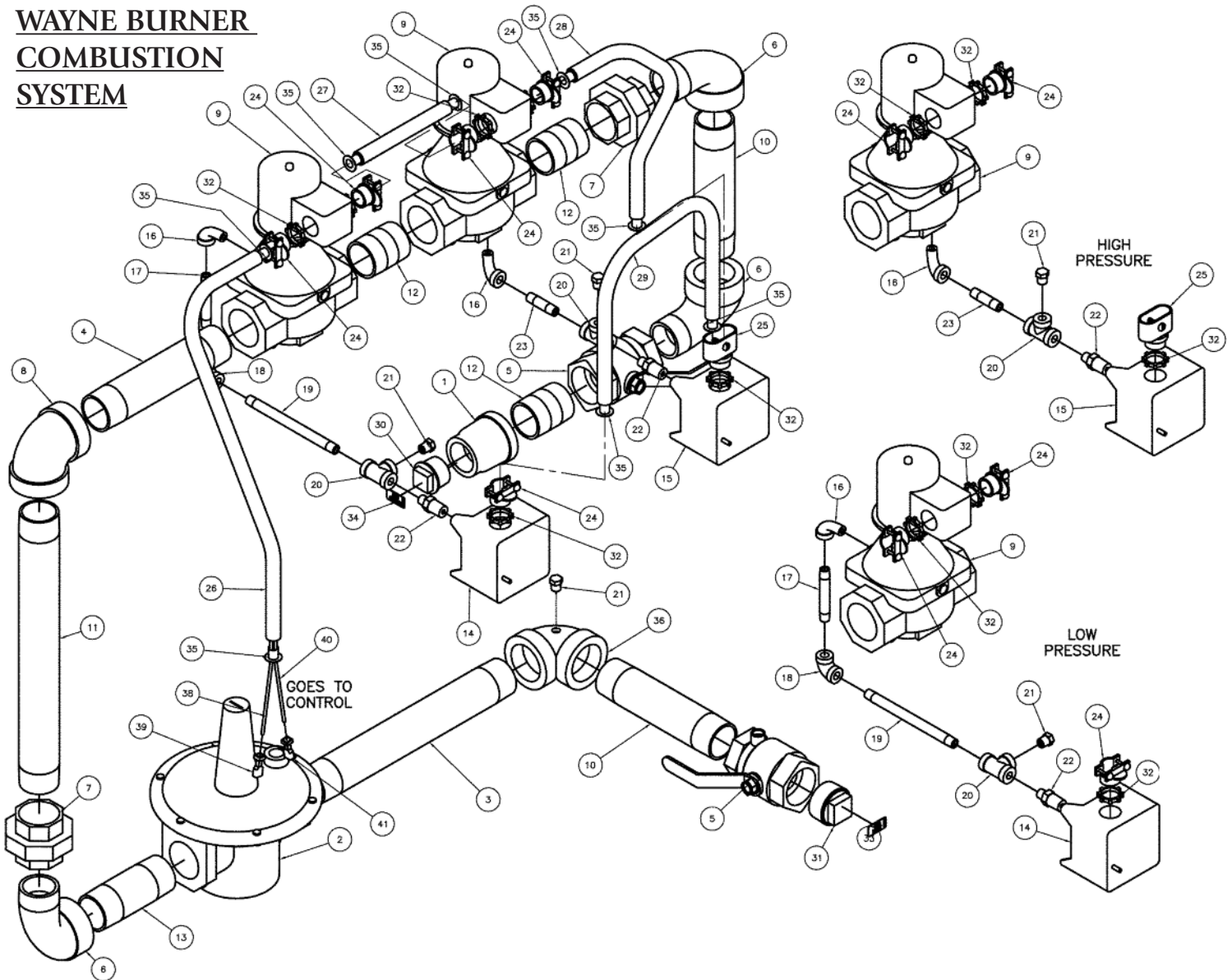

Figure 21

WAYNE BURNER COMBUSTION SYSTEM



ITEM	PART#	DESCRIPTION
1	HWP 63751-001	Reducer, Bell 1" x 1-1/4"
2	HWP 63262-004	Regulator, Gas Pressure
3	HWP 63752-008	Nipple, 1-1/4" x 11"
4	HWP 63752-004	Nipple, 1-1/4" x 7"
5	HWP 63756-001	Valve, Manual Ball 1-1/4"
6	HWP 63947-001	Elbow, 1-1/4" 90°
7	HWP 63755-001	Union, 1-1/4"
8	HWP 63948-001	Elbow, 1-1/4" 90° Female
9	HWP 63759-001	Valve, Gas Safety Sutoff 1-1/4"
10	HWP 63752-003	Nipple, 1-1/4" x 6-1/2"
11	HWP 63752-006	Nipple, 1-1/4" x 13-1/2"
12	HWP 63752-001	Nipple, 1-1/4" x 2"
13	HWP 63752-007	Nipple, 1-1/4" x 4"
14	HWP 63513-001A	Switch, Gas Pressure Low
15	HWP 63513-002A	Switch, Gas Pressure High
16	HWP 13385	Elbow, Street 1/8"NPT
17	HWP 100462-004	Nipple, Pipe 1/8" x 2-1/2"
18	HWP 63719-001	Elbow, Pipe 90° ELL 1/8"NPT
19	HWP 100462-005	Nipple, Pipe 1/8" x 5"
20	HWP 63521-002	Tee, 1/8" Blk Pipe

ITEM	PART#	DESCRIPTION
21	HWP 101275-001	Plug, Hex Head 1/8 Brass
22	HWP 63526-001	Nipple, Hex 1/4" x 1/8"
23	HWP 100462-001	Nipple, Pipe 1/8" x 1-1/2"
24	HWP 13801	Fitting, Conduit 3/8
25	HWP 14429	Connector, Duplex Conduit
26	HWP 100196-024	Conduit, Flex 3/8" x 13"
27	HWP 100196-003	Conduit, Flex 3/8" x 5"
28	HWP 100196-006	Conduit, Flex 3/8" x 10"
29	HWP 100196-019	Conduit, Flex 3/8" x 12"
30	HWP 63523-001	Plug, P88H 1" Plastic
31	HWP 63523-002	Plug, P108 1-1/4" Plastic
32	HWP 12910	Locknut, Conduit
33	HWP 63528-001	Decal, Gas Inlet
34	HWP 63528-002	Decal, Gas Outlet
35	HWP 13660	Bushing, ASB-1
36	HWP 63958-001	Elbow, 1-1/4" 90°
38	HWP 62411-073	Wire, Black 16GA
39	HWP 63012-001	Terminal Female .250 Insulated
40	HWP 62411-083	Wire, White 16GA
41	HWP 63012-002	Terminal, Male .250 Insulated

MIDCO BURNER VG1000

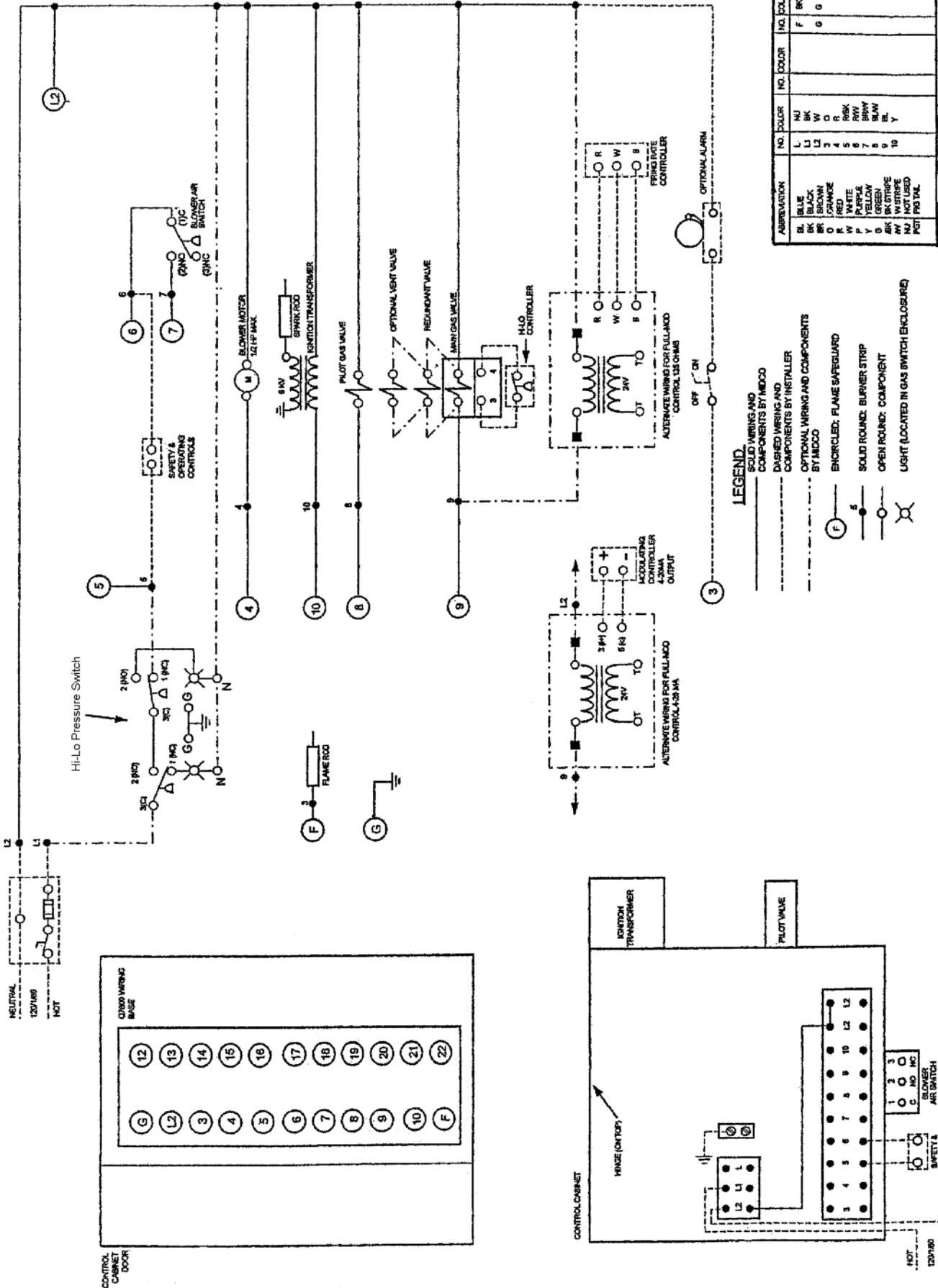

ABBREVIATION	NO.	COLOR	NO.	COLOR	NO.	COLOR
BL	1	BLACK	L	1		
BK	2	BLACK	L	2		
BR	3	BROWN	L	3		
CR	4	RED	L	4		
P	5	PURPLE	L	5		
W	6	WHITE	L	6		
Y	7	YELLOW	L	7		
GR	8	GREEN	L	8		
OR	9	ORANGE	L	9		
AV	10	ALUMINUM STRIPE	L	10		
NJ		NOT LISTED				
PRT		PIG TAIL				
					F	BK/FR
					G	G

LEGEND:
 ——— SOLID WIRING AND COMPONENTS BY MIDCO
 - - - - - DASHED WIRING AND COMPONENTS BY INSTALLER
 - - - - - OPTIONAL WIRING AND COMPONENTS BY MIDCO
 ○ ENCIRCLED: FLAME SAFEGUARD
 ● SOLID ROUND: BURNER STRIP
 ○ OPEN ROUND: COMPONENT
 LIGHT (LOCATED IN GAS SWITCH ENCLOSURE)



WAYNE BURNER - Serial No. M5895 & Beyond

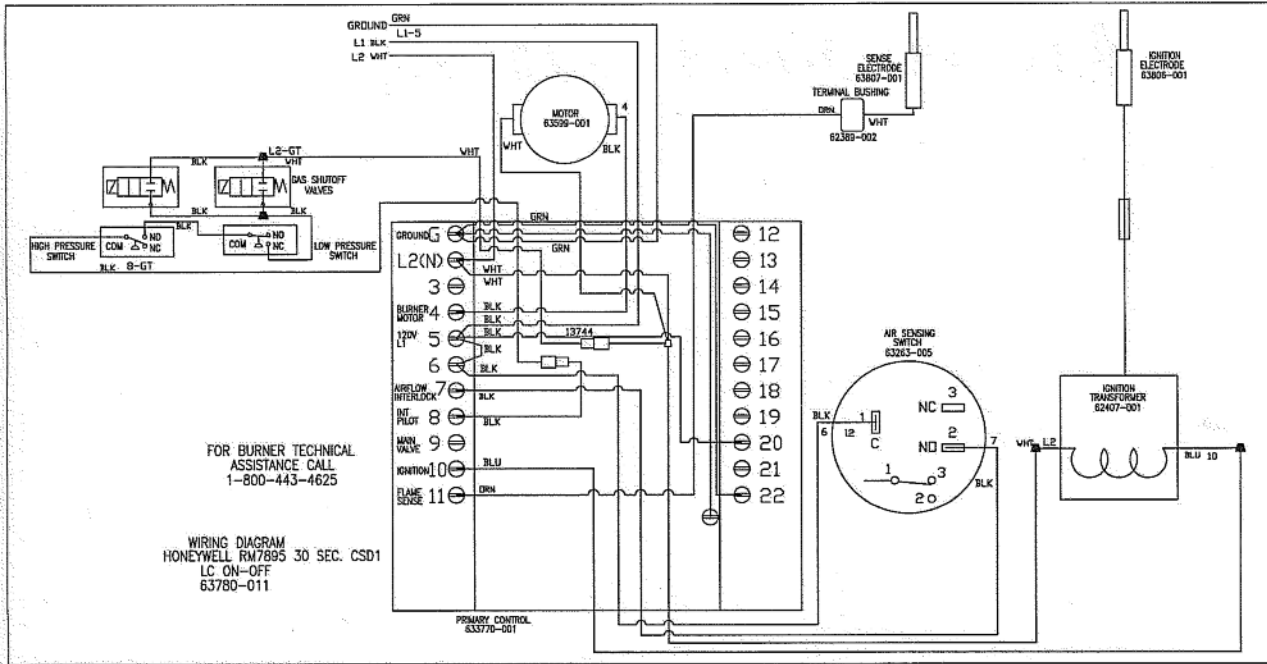

WAYNE BURNER - Serial No. M5659 & Lower

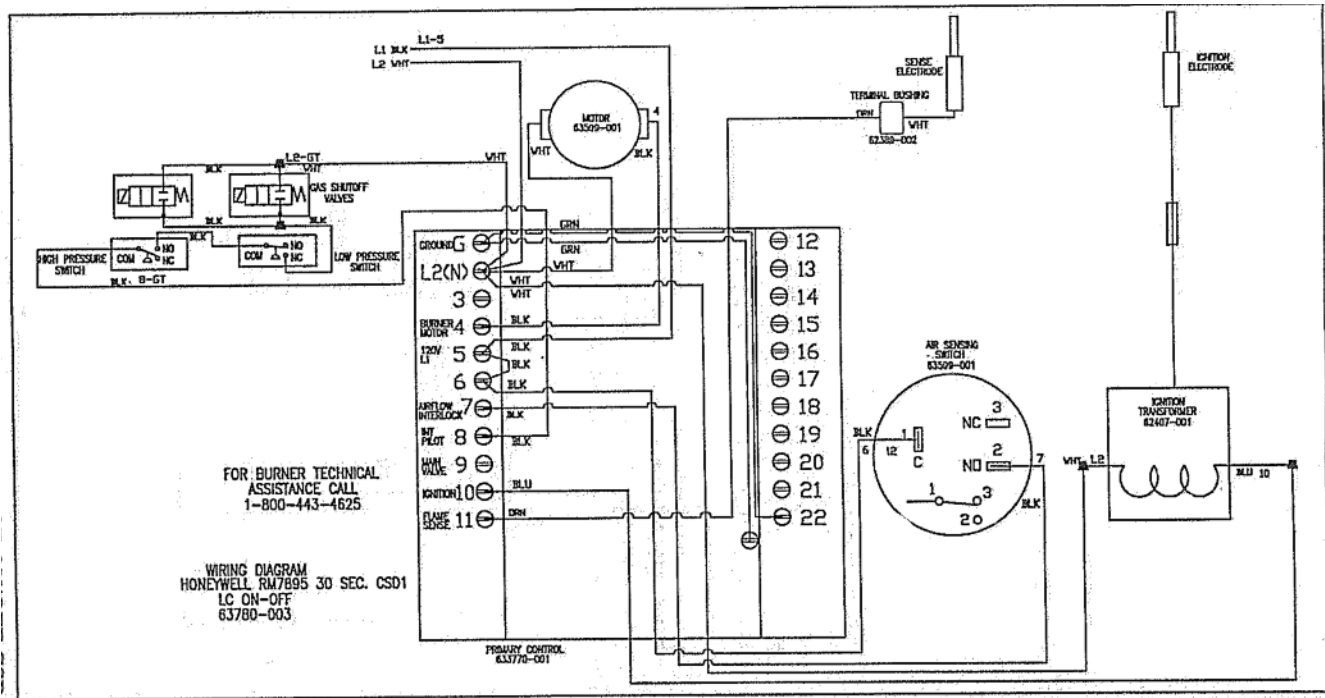

MIDCO BURNER VG1000

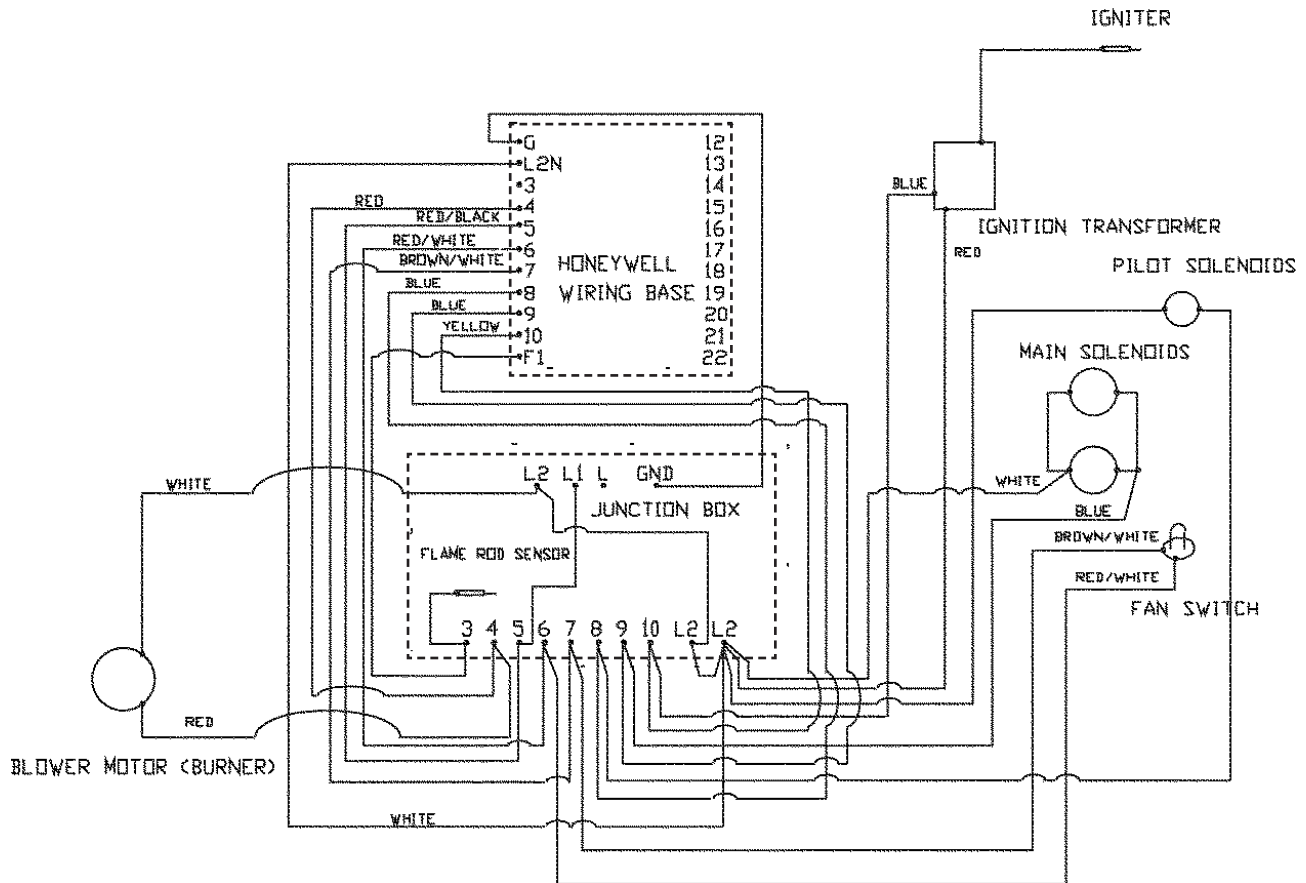

SENSOR RESISTANCE CHART

Degrees Farenheight	Degrees Celcius	Resistance (1K Ohm Scale)*	Degrees Farenheight	Degrees Celcius	Resistance (1K Ohm Scale)*
-40	-40	330.6	185	85	1.07
-31	-35	239	194	90	0.9156
-22	-30	174.7	203	95	0.7862
-13	-25	129	212	100	0.6777
-4	-20	96.21	221	105	0.5863
5	-15	72.42	230	110	0.5089
14	-10	55.01	239	115	0.4433
23	-5	42.14	248	120	0.3873
32	0	32.55	257	125	0.3395
41	5	25.34	266	130	0.2985
50	10	19.87	275	135	0.2633
59	15	15.7	284	140	0.2328
68	20	12.49	293	145	0.2065
77	25	10	302	150	0.1836
86	30	8.059	311	155	0.1636
95	35	6.534	320	160	0.1455
100	40	5.329	329	165	0.1303
113	45	4.371	338	170	0.1169
122	50	3.604	347	175	0.1052
131	55	2.988	356	180	0.09484
140	60	2.489	365	185	0.08569
149	65	2.084	374	190	0.07757
158	70	1.753	383	195	0.07037
167	75	1.481	392	200	0.06396
176	80	1.256			

* Correct Ohm reading when sensors are at the above listed temperatures

CONTROL BOX MAIN CIRCUIT DIAGRAM

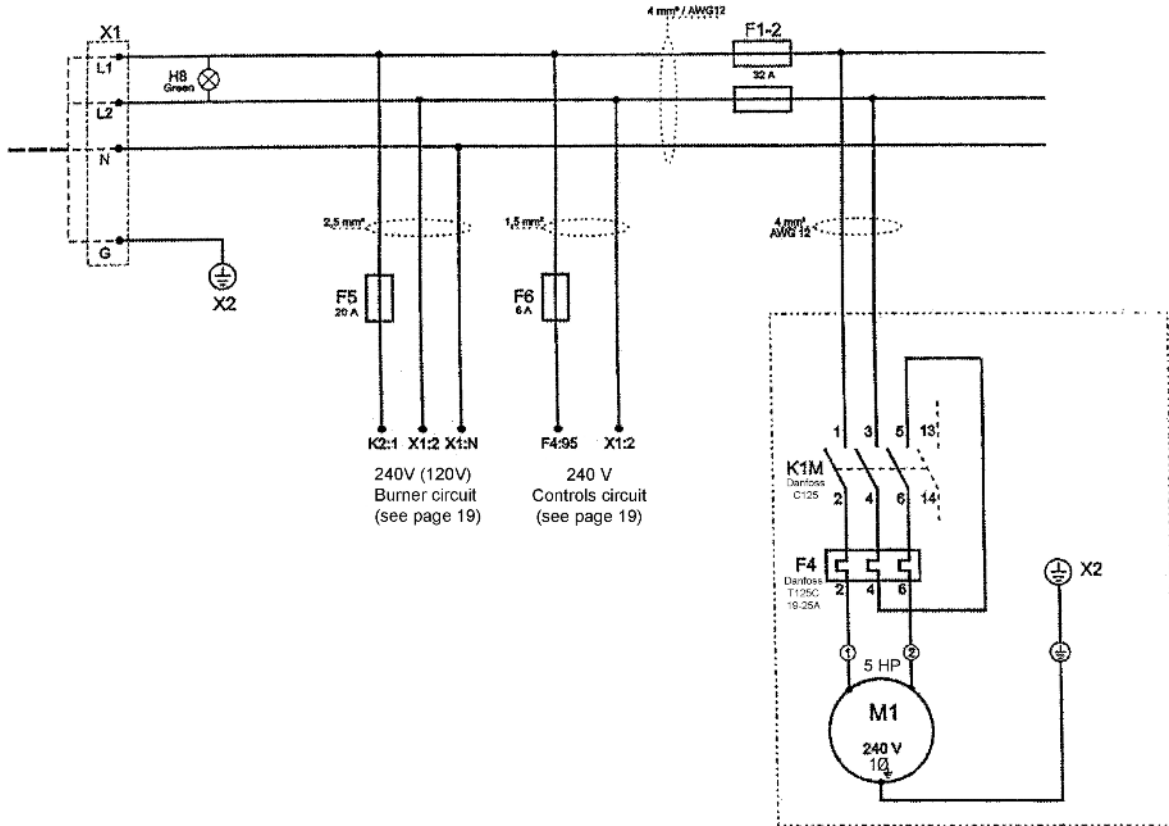

CONTROL BOX WIRING DIAGRAM

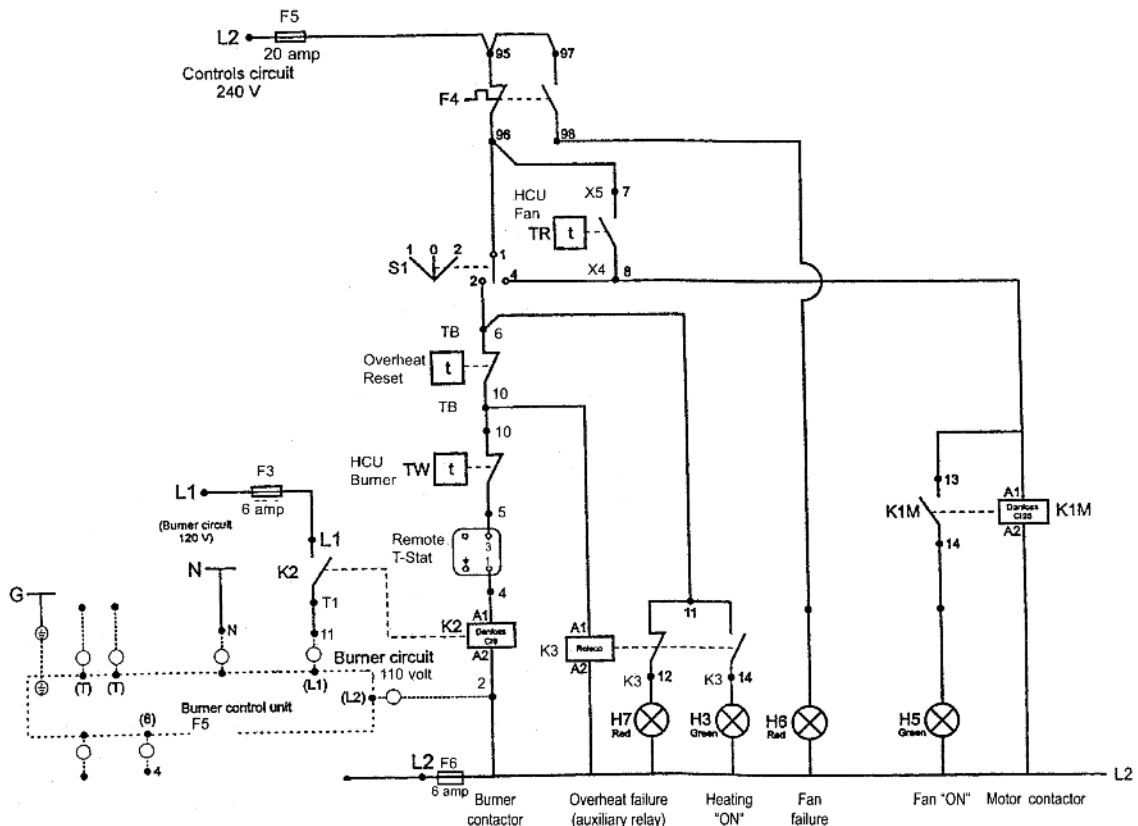

CONTROL BOX WIRING

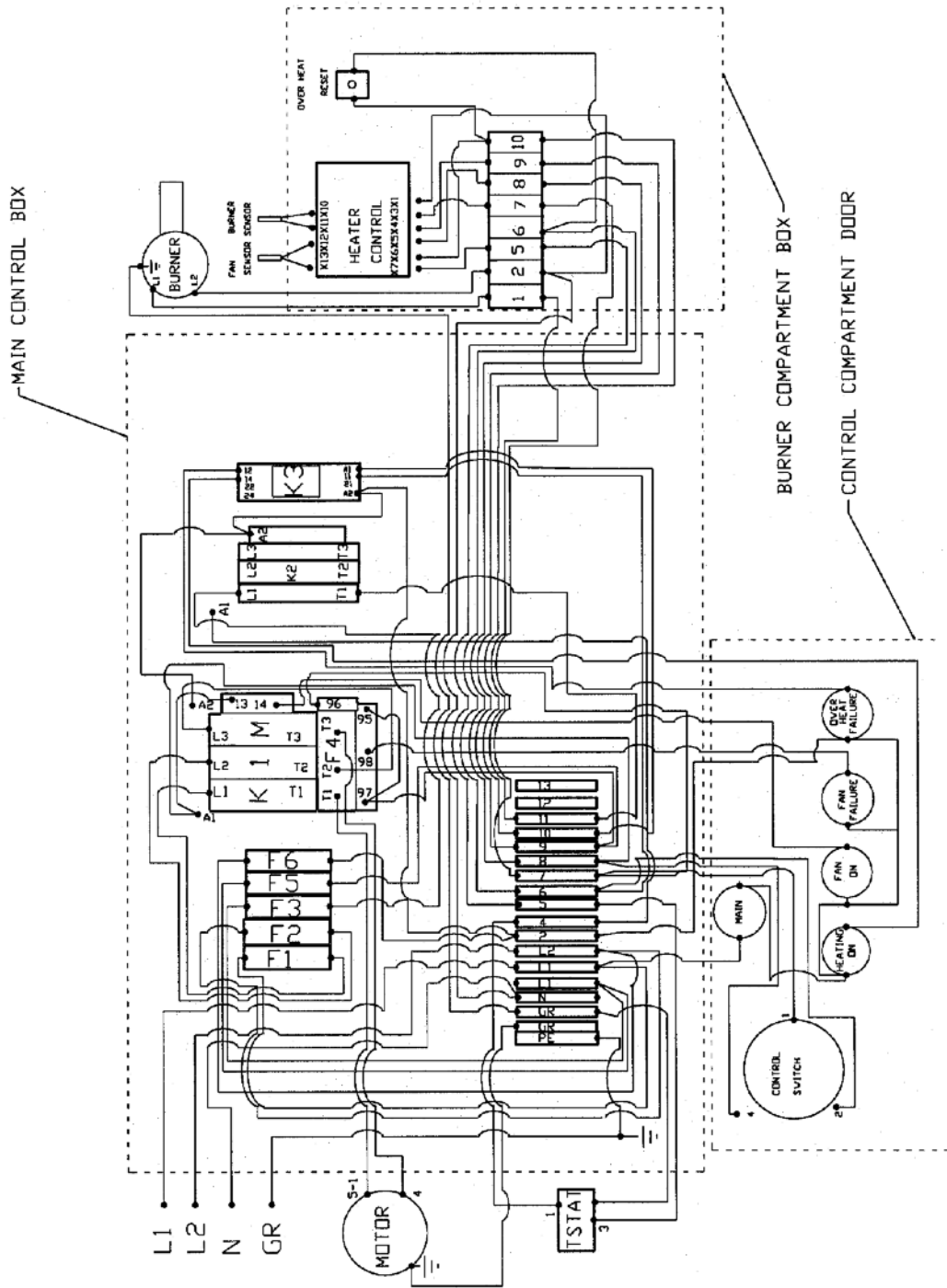

CONTROL BOX PARTS

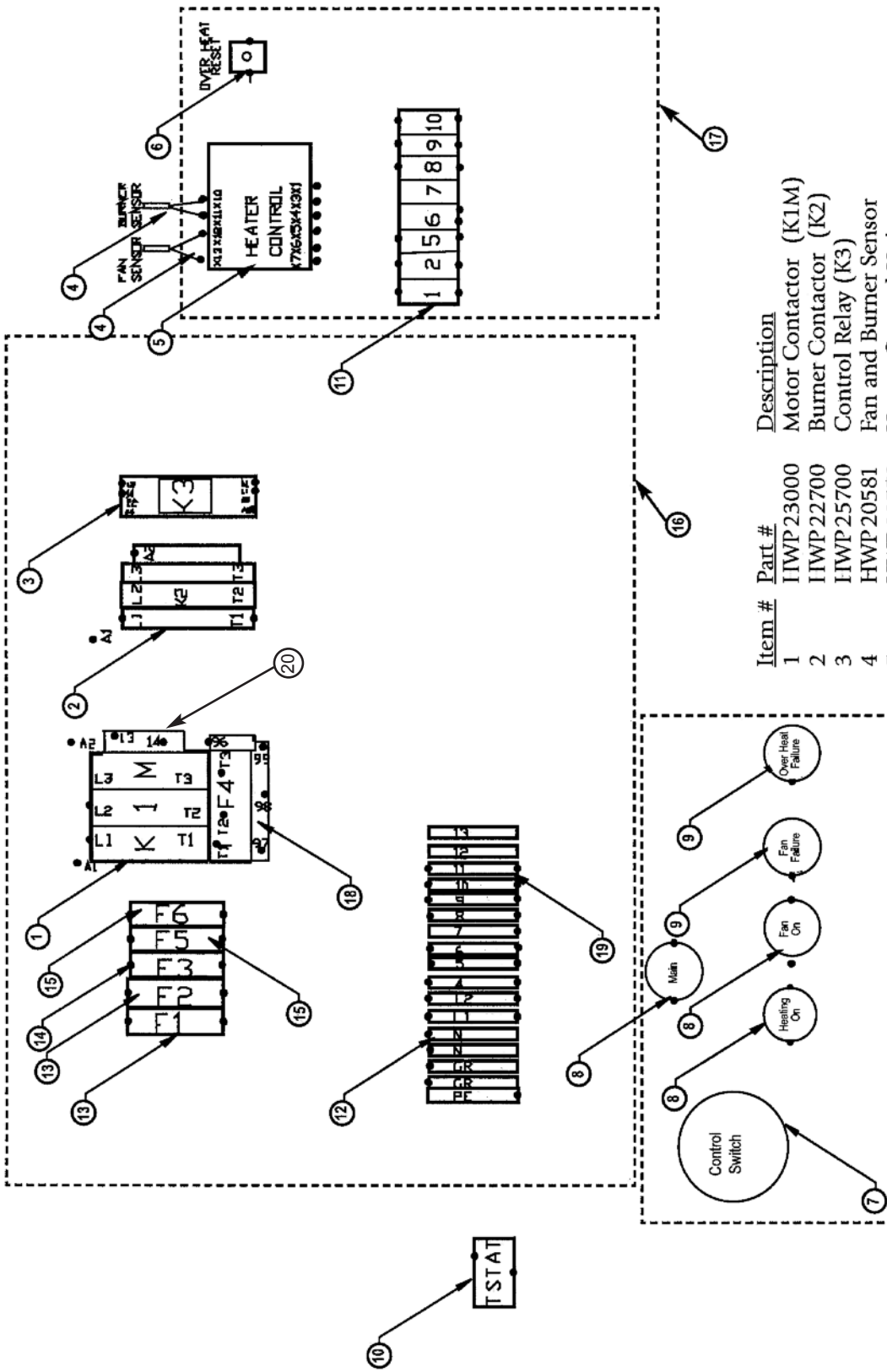

Item #	Part #	Description
1	IWP 23000	Motor Contactor (K1M)
2	IWP 22700	Burner Contactor (K2)
3	IWP 25700	Control Relay (K3)
4	HWP 20581	Fan and Burner Sensor
5	IWP 20579	Heater Control Unit
6	IWP 21400	Over Heat Reset
7	HWP 120021	Control Switch
8	HWP 44120	Light Green
9	IWP 44110	Light Red
10	HWP 2453	Thermostat
11	HWP 36701	Terminal Block (Heater Control)
12	HWP 36609	Terminal Block (Control Box) 6mm
13	HWP 38107	Circuit Breaker 32 AMP (F1-F2)
14	HWP 38105	Circuit Breaker 20 AMP (F3)
15	HWP 38090	Circuit Breaker 6 AMP (F5-F6)
16	IWP 40500	Main Control Box (Box Only)
17	HWP 210080	Thermostat Box (Box Only)
18	HWP 38209	Thermal Relay (F4)
19	HWP 36610	Terminal Block (Control Box) 4mm
20	HWP 22211	Aux Contact

EXHAUST FLUE PIPE GUIDELINES

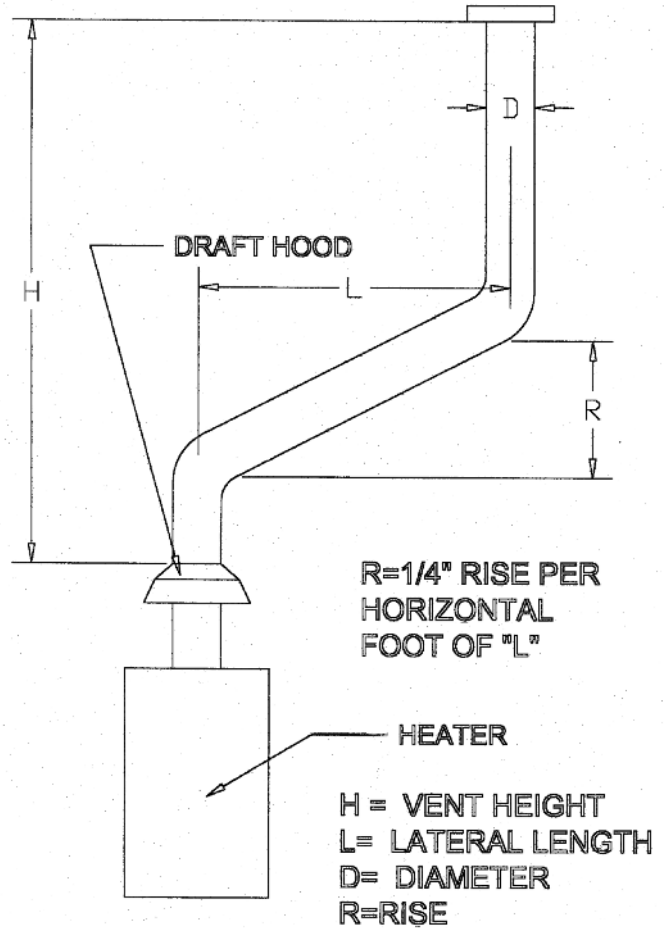
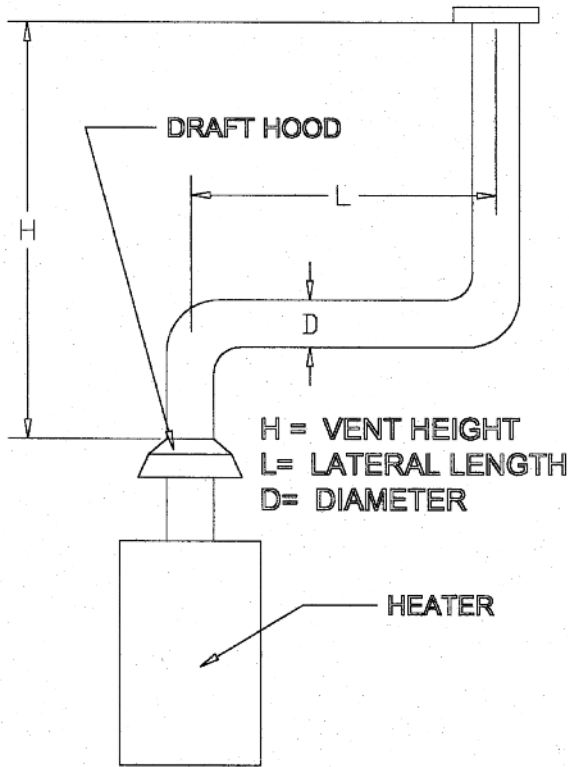

**CAPACITY OF
TYPE B DOUBLE-WALL
VENTS SERVING
A SINGLE DRAFT
HOOD-HEATER
x 1000 BTU'S**

**FOR INDOOR
APPLICATIONS**

TOTAL VENT HEIGHT (H) FEET	LATERAL LENGTH (L) FEET	VENT DIAMETER (D) INCHES							
		10	12	14	16	18	20	22	24
6	0	NR	850	1170	1530	1960	2430	2950	3520
	2	NR	650	890	1170	1480	1850	2220	2670
	6	NR	630	870	1150	1470	1820	2210	2650
	12	NR	610	840	1110	1430	1795	2180	2600
8	0	NR	970	1320	1740	2220	2750	3360	4010
	2	NR	745	1020	1340	1700	2110	2560	3050
	8	NR	720	1000	1320	1670	2070	2530	3030
	16	NR	685	950	1260	1600	2035	2470	2960
10	0	NR	1060	1450	1925	2450	3050	3710	4450
	2	NR	850	1130	1480	1890	2340	2840	3390
	10	NR	795	1080	1430	1840	2280	2780	3340
	20	NR	735	1030	1360	1780	2230	2720	3250
15	0	NR	1240	1720	2270	2900	3620	4410	5300
	2	NR	985	1350	1770	2260	2800	3410	4080
	15	NR	905	1250	1675	2150	2700	3300	3980
	30	NR	845	1180	1550	2050	2620	3210	3840
20	0	NR	1350	1900	2520	3250	4060	4980	6000
	2	NR	1100	1520	2000	2570	3200	3910	4700
	10	NR	1045	1460	1940	2500	3130	3830	4600
	20	NR	990	1390	1880	2430	3050	3760	4550
30	30	NR	945	1270	1700	2330	2980	3650	4390
	0	1060	1550	2170	1920	3770	4750	5850	7060
	2	865	1310	1800	1380	3050	3810	4650	5600
	20	784	1185	1650	2200	2870	3650	4480	5310
	40	705	1075	1520	2060	2700	3480	4270	5140

We Stock A Complete Line Of Parts & Accessories



DUCTING

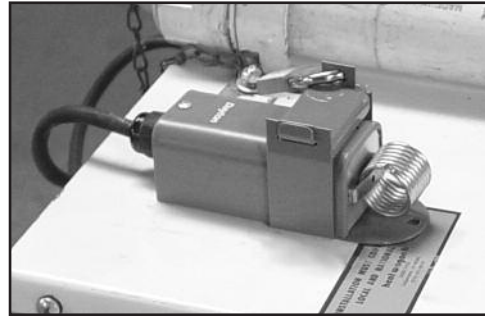

THERMOSTAT
LOCK BOXES



HOSES



REGULATORS



342 N. Co. Rd. 400 East

Valparaiso, IN 46383

219-464-8818 • Fax 219-462-7985

www.heatwagon.com