

# SHAC1811

## Legend

- 1 Return Air
- 2 Control Pad
- 3 Cold Air Supply
- 4 Condenser Air Inlet
- 5 Condenser Air Outlet
- 6 Power Cord
- 7 Condensate Nipple
- 8 Condensate Alarm Jack
- 9 Access Door

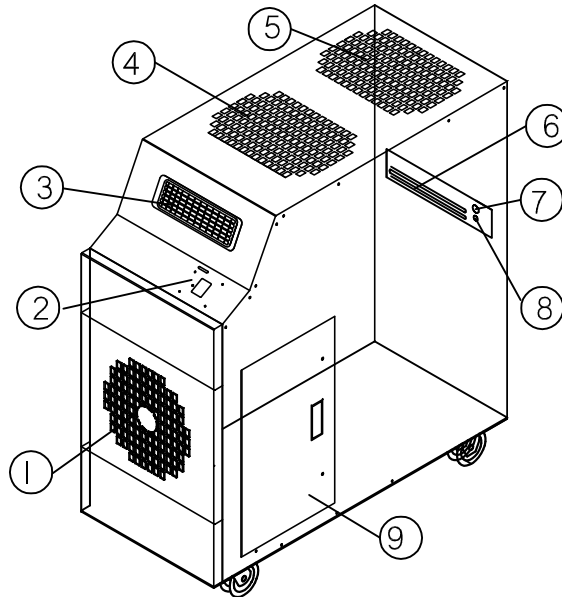

Isometric View

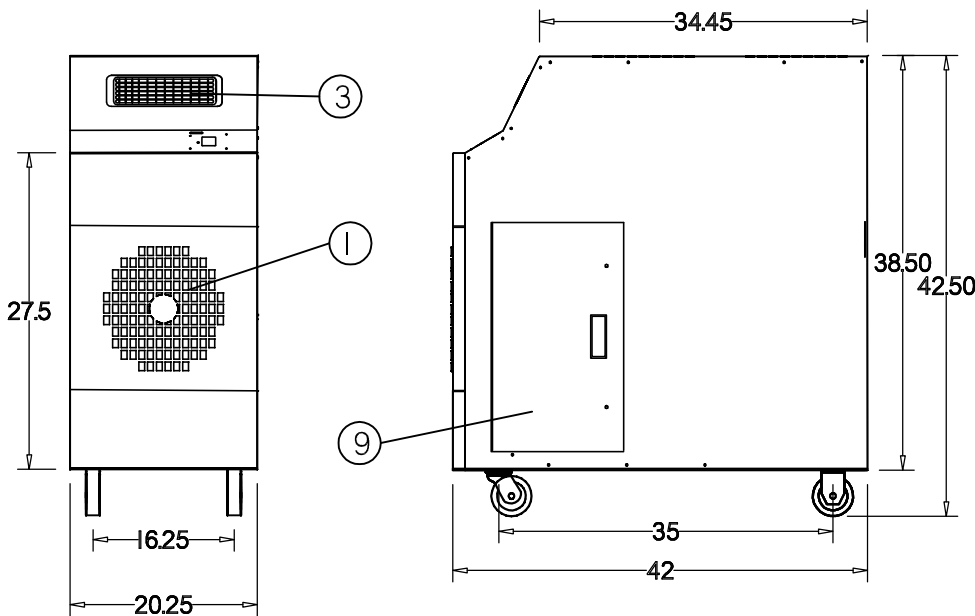

Front View

Right View



ETL LISTED CONFORMS TO ANSIUL  
1995 CERTIFIED TO CAN/CSAA22.2 NO.235



1-800-KWIKOOL

## Model SHAC1811 - 1.5 Ton

HEATING & COOLING CAPACITY		
COOLING	BTU/hr @ 95 F at 60%RH	17,700 (1-1/2 TON)
HEATING	BTU/hr @ 55 F at 60%RH	21,240 (1.77 TONS)
COMPRESSOR DATA		
	Compressor Type	HERMETIC ROTARY
COOLING	Operating Temperatures	60-105 F 50%RH
HEATING	Operating Temperatures	45-80 F 50%RH
	Non-CFC Refrigerant Charge (Lbs.)	R421A
FAN DATA		
EVAPORATOR		
	Fan Type (Centrifugal)	DIRECT DRIVE
	Air Flow (CFM)	600/Single Speed
	Supply Air Output Type	ADJUSTABLE VENT
	Supply Air Chute Data (Optional)	2-6" Dia. x 15" Length
CONDENSER		
	I/O Intergral Condenser - In/Out	BALANCED AIR FLOW
	Fan Type (Centrifugal)	DIRECT DRIVE
	Air Flow (CFM)	950
	Condenser Duct Data (Optional)	2x14" Dia. x 8' Length
	Condenser Duct Max. Length	25'
ELECTRICAL DATA		
	Power Supply (Volts)	115/Single Phase
	Current Consumption (Amps)	17.9
	Power Consumption (KW)	1.35
	Maximum Circuit Breaker (Amps)	20
	Minimum Circuit Ampacity (Amps)	20
	Min/Max Voltage	105-125
	Power Cord Gauge/Length	12/6'
	Plug Configuration	NEMA 5-20P
DIMENSIONAL DATA		
Unitary Models	Width x Depth x Height (Inches)	20.25X42X42.5
	Weight (Lbs.)	278
	Shipping Weight (Lbs.)	353
	Ceiling Kit - CK-24 Weight	47
	Total Shipping Weight/w Ceiling Kit	415
SAFETY DEVICE DATA		
	Compressor Overload	INTERNAL
	Fan Motor Overload	AUTOMATIC INTERNAL
	Evaporator Freeze-up	HOT GAS BYPASS
	High Pressure Switch	MANUAL
	Low Pressure Switch	AUTOMATIC
	Compressor Short Cycle	YES
	Automatic Restart	YES
	Thermostat	MICROPROCESSOR/ DIGITAL
	Condensate Pump w 20' Head Pres.	YES
	Condensate Pump Overflow	YES
	Condensate Tank Overflow	YES



**1-800-KWIKOOL**