

# KWIB3021

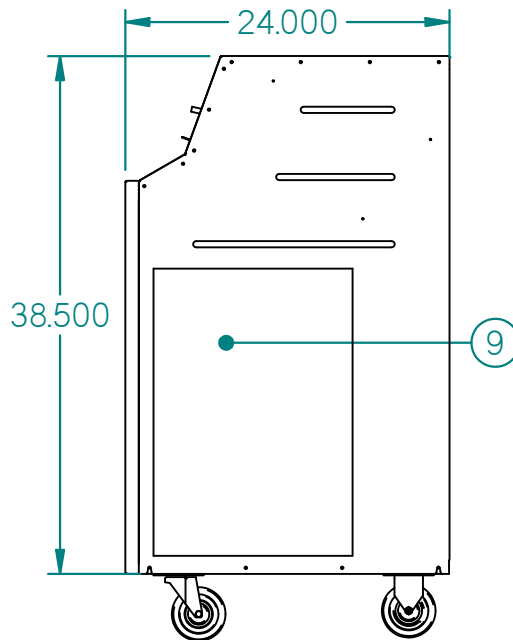

- 1 Cold Air Return
- 2 Control Pad
- 3 Cold Air Supply
- 4 Water Inlet
- 5 Water Outlet

- 6 Power Cord
- 7 Condensate Nipple
- 8 Condensate Alarm Jack
- 9 Access Door
- 10 Vent Control

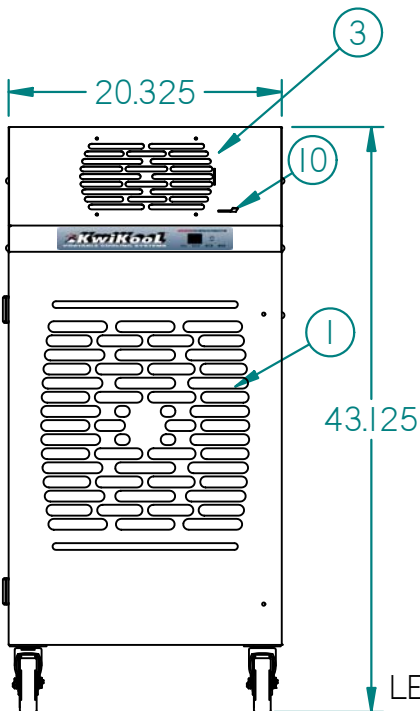
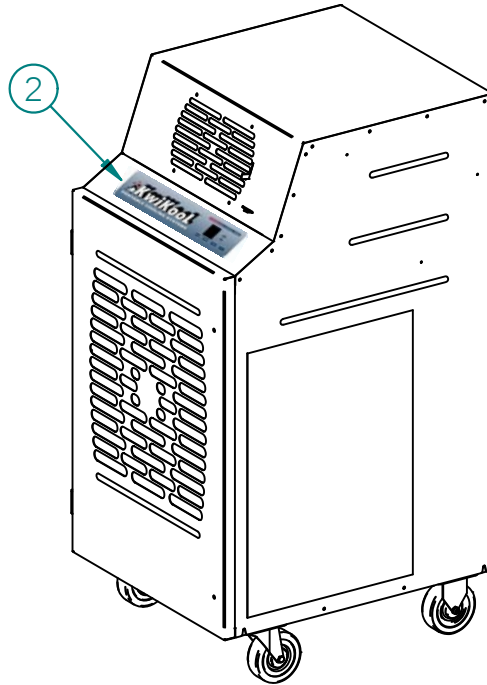
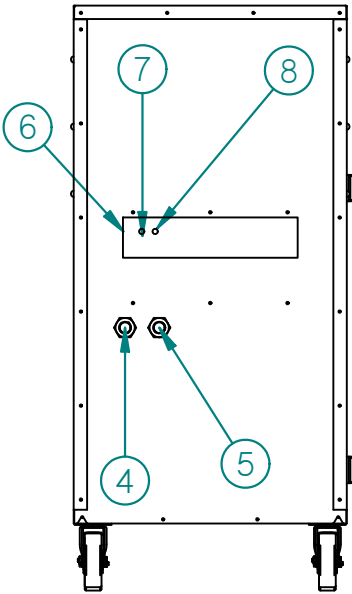

# SPECIFICATIONS

# KWIB3021 - 2.5 Ton

<b>COOLING CAPACITY</b>		
	BTU/hr @ 95F at 60% RH	29,500 (2.5 Ton)
<b>COMPRESSOR DATA</b>		
	Compressor Type	Hermetic Recip.
	Operating Temperatures	60-110 F 50%RH
	Refrigerant	407C
<b>FAN DATA</b>		
<b>Evaporator</b>		
	Fan Type (Centrifugal)	Direct Drive
	Air Flow (CFM)	850/3 Speed
	Supply Air Device	Adjustable Vent
	Supply Air Chute Kit (optional)	2 - 6" Dia. x 15" Length
<b>Water Flow Data</b>		
	Flow Regulation Valve	Automatic
	Inlet Water 85F-95F Exit (GPM)	7.5
	Inlet Water 75F-95F Exit (GPM)	3.75
	Inlet Water 65F-95F Exit (GPM)	2.5
	Inlet Water 55F-95F Exit (GPM)	2
<b>ELECTRICAL DATA</b>		
	Power Supply (Volts)	208/230 - Single Phase
	Current Consumption (Amps)	12.65/11.5
	Power Consumption (KW)	2.25
	Maximum Circuit Breaker (Amps)	20
	Minimum Circuit Capacity(Amps)	14.45
	Min./Max. Voltage	195-225/210-250
	Power Cord Gauge/Length	12AWG/6'
	Plug Configuration	NEMA 6-20
<b>DIMENSIONAL DATA</b>		
	Width x Depth x Height (Inches)	20.325" x 24" x 43.125"
	Weight (Lbs.)	208
	Shipping Weight (Lbs.)	283
<b>SAFETY DEVICE DATA</b>		
	Compressor Overload	Internal
	Fan Motor Overload	Automatic Internal
	Evaporator Freeze Protection	Hot Gas Bypass
	High Pressure Switch	Manual
	Low Pressure Switch	Automatic
	Compressor Short Cycle	Yes
	Automatic Restart	Yes
	Thermostat Type	Microprocessor/Digital
	Condensate Pump Overflow	Yes
	Condensate Tank Overflow	Yes

**1-800-KWIKOOL**