

KWIB2411

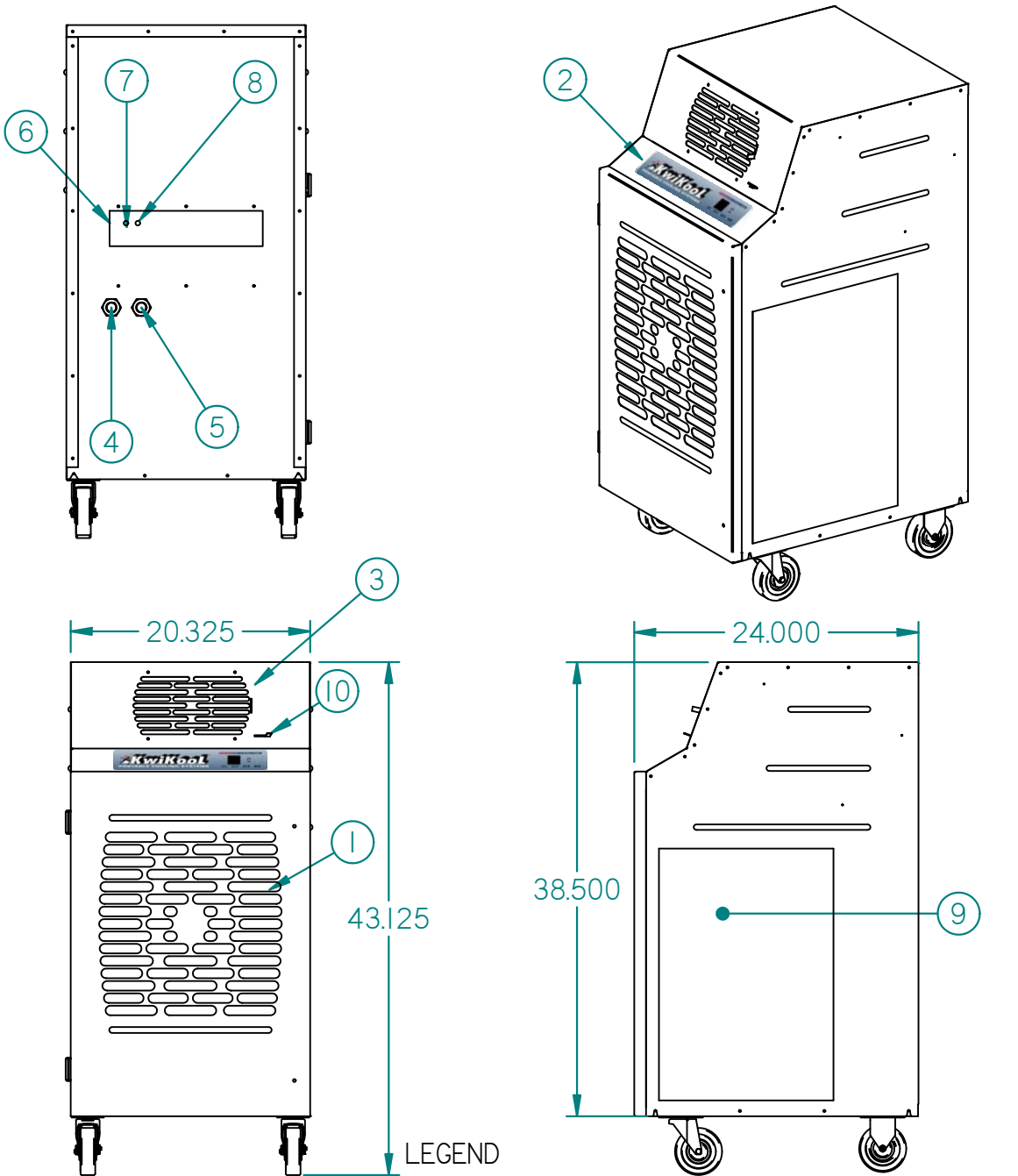

- | | |
|-------------------|-------------------------|
| 1 Cold Air Return | 6 Power Cord |
| 2 Control Pad | 7 Condensate Nipple |
| 3 Cold Air Supply | 8 Condensate Alarm Jack |
| 4 Water Inlet | 9 Access Door |
| 5 Water Outlet | 10 Vent Control |



SPECIFICATIONS

KWIB2411 - 2 Ton

COOLING CAPACITY		
	BTU/hr @ 95F at 60% RH	23,500 (2 Tons)
COMPRESSOR DATA		
	Compressor Type	Hermetic Recip.
	Operating Temperatures	60-110 F 50%RH
	Refrigerant	407C
FAN DATA		
Evaporator		
	Fan Type (Centrifugal)	Direct Drive
	Air Flow (CFM)	750/Single Speed
	Supply Air Device	Adjustable Vent
	Supply Air Chute Kit (optional)	2 - 6" Dia. x 15" Length
Water Flow Data		
	Flow Regulation Valve	Automatic
	Inlet Water 85F-95F Exit (GPM)	6
	Inlet Water 75F-95F Exit (GPM)	3
	Inlet Water 65F-95F Exit (GPM)	2
	Inlet Water 55F-95F Exit (GPM)	1.5
ELECTRICAL DATA		
	Power Supply (Volts)	115/Single Phase
	Current Consumption (Amps)	17.1
	Power Consumption (KW)	1.65
	Maximum Circuit Breaker (Amps)	20
	Minimum Circuit Capacity(Amps)	17.76
	Min./Max. Voltage	105-125
	Power Cord Gauge/Length	12AWG/6'
	Plug Configuration	NEMA 5-20
DIMENSIONAL DATA		
	Width x Depth x Height (Inches)	20.325" x 24" x 43.125"
	Weight (Lbs.)	212
	Shipping Weight (Lbs.)	287
SAFETY DEVICE DATA		
	Compressor Overload	Internal
	Fan Motor Overload	Automatic Internal
	Evaporator Freeze Protection	Hot Gas Bypass
	High Pressure Switch	Manual
	Low Pressure Switch	Automatic
	Compressor Short Cycle	Yes
	Automatic Restart	Yes
	Thermostat Type	Microprocessor/Digital
	Condensate Pump Overflow	Yes
	Condensate Tank Overflow	Yes

1-800-KWIKOOL