

KIB3021

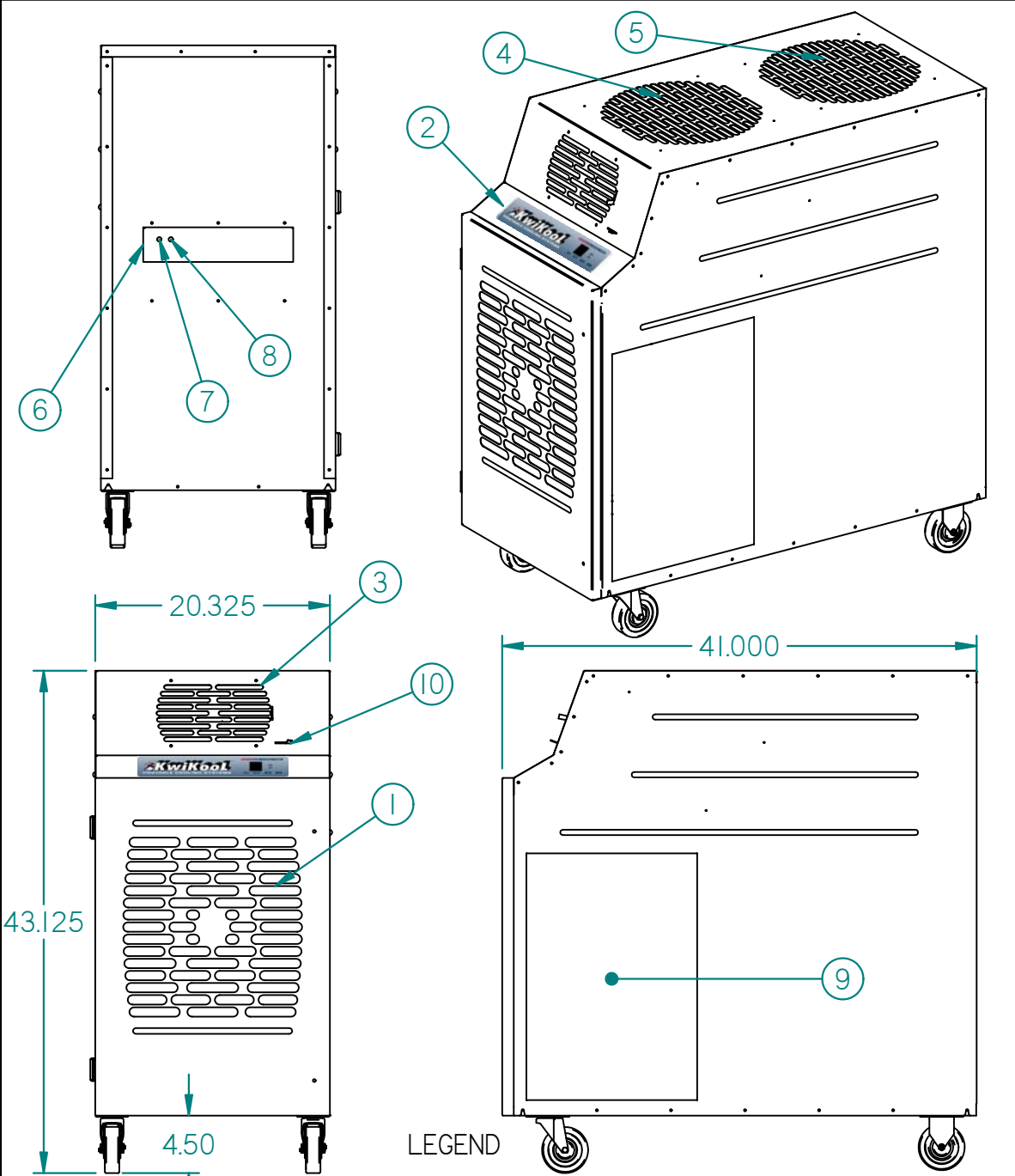

LEGEND

- | | |
|------------------------|-------------------------|
| 1 Cold Air Return | 6 Power Cord |
| 2 Control Pad | 7 Condensate Nipple |
| 3 Cold Air Supply | 8 Condensate Alarm Jack |
| 4 Condenser Air Inlet | 9 Access Door |
| 5 Condenser Air Outlet | 10 Vent Control |



SPECIFICATIONS

KIB3021 - 2.5 Ton

COOLING CAPACITY		
	BTU/hr @ 95F at 60% RH	29,500 (2.5 Tons)
COMPRESSOR DATA		
	Compressor Type	Hermetic Recip.
	Operating Temperatures	60-110 F 50%RH
	Refrigerant	407C
FAN DATA		
Evaporator		
	Fan Type (Centrifugal)	Direct Drive
	Air Flow (CFM)	850/3 Speed
	Supply Air Device	Adjustable Vent
	Supply Air Chute Kit (optional)	2 - 6" Dia. x 15" Length
Condenser		
	I/O Integral Condenser	Balanced Air Flow
	Fan Type (Centrifugal)	Direct Drive
	Air Flow (CFM)	1400
	Condenser Duct Specs (optional)	2 - 14" Dia. x 8' Length
	Condenser Duct Max. Length	40'
ELECTRICAL DATA		
	Power Supply (Volts)	208/230 Single Phase
	Current Consumption (Amps)	17.05/15.5
	Power Consumption (Watts)	3.05
	Maximum Circuit Breaker (Amps)	20
	Minimum Circuit Capacity(Amps)	17.35
	Min./Max. Voltage	195-225/210-250
	Power Cord Gauge/Length	12AWG/6'
	Plug Configuration	NEMA 6-20
DIMENSIONAL DATA		
	Width x Depth x Height (Inches)	20.325" x 41" x 43.125"
	Weight (Lbs.)	294
	Shipping Weight (Lbs.)	379
	Ceiling Kit Weight (Lbs.)	47
	Shipping Weight w/ Ceiling Kit	441
SAFETY DEVICE DATA		
	Compressor Overload	Internal
	Fan Motor Overload	Automatic Internal
	Evaporator Freeze Protection	Hot Gas Bypass
	High Pressure Switch	Manual
	Low Pressure Switch	Automatic
	Compressor Short Cycle	Yes
	Automatic Restart	Yes
	Thermostat Type	Microprocessor/Digital
	Condensate Pump Overflow	Yes
	Condensate Tank Overflow	Yes

1-800-KWIKOOL